



**INSTALLATION
USE AND
MAINTENANCE
MANUAL**

B 350 A





DECLARATION OF CONFORMITY "CE"

(Directive 98/37 cee, attached 2 part A)

WWW.BIROSAW.COM

**THE BIRO MANUFACTURING COMPANY, 1114 W. MAIN ST., MARBLEHEAD,
OH 43440-2099 U.S.A.**

Model: B 350 A

CE

s/n: _____



Compliant to NSF/ANSI Standard 8: Commercial powered food preparation equipment.

This machine was designed and built to slice food in compliance to the norms of the 89/392 - 89/336 Directive and following amendments CE 91/368 - 93/44 - 93/68 CE, EN 1974 directive 89/109.

*Materials and objects destined to the food products contact directive (89/109 CEE) and subsequent modification (2002/72/CEE)

*EN 60204-1 Machines electrical equipments

*EN 60335-2-64 Particular requisition for kitchen machines

SLICING MACHINES

AUTOMATIC VERSION B 350 A

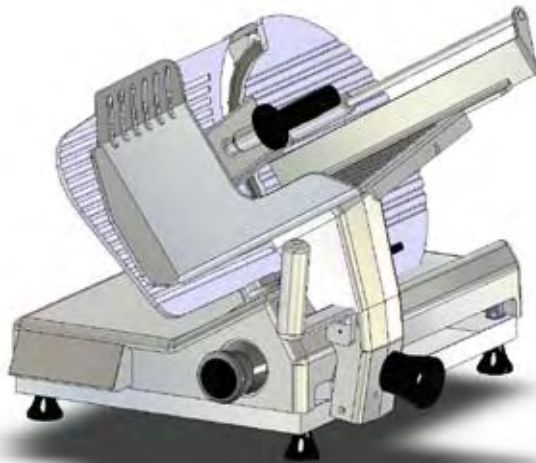

This manual consists of 29 pages as follows:

- Title page with notes for the user;
- Contents, page 3;
- Page 4 to page 28 carrying progressive numeration

CONTENTS

FOREWORD	4
SCOPE OF THIS MANUAL	4
GENERAL INFORMATION	4
LIMITS OF USE – SAFETY NORMS	4
GENERAL SAFETY REGULATIONS	4
MANUFACTURER'S WARRANTY AND LIABILITY	5
PLATES – CONFORMITY MARKS	5
ENVIRONMENTAL CONDITIONS OF USE	5
PACKING	6
OPENING THE BOX	6
TECHNICAL DESCRIPTION AND PROPOSED CONDITIONS OF USE	7
GENERAL DESCRIPTION	7
MECHANICAL AND ELECTRICAL SAFETY DEVICES	7
WARNING: RESIDUAL RISKS	7
DIMENSIONS	7
MAIN TECHNICAL DATA	7
SUPPLIED LITERATURE AND ACCESSORIES	7
PRODUCTS THAT CAN BE SLICED	7
PRODUCTS THAT MUST NOT BE SLICED	7
DIMENSION MAIN TECHNICAL DATA	8
MAIN COMPONENTS	
LAYOUT CONTROL PANEL	8
MACHINE COMMISSIONING AND FUNCTION TESTS	10
INSTALLING THE MACHINE	10
ELECTRICAL CONNECTION	10
COMMANDS	10
USING THE MACHINE	11
LOADING THE PRODUCT ON THE TRAY AND SLICING	11
PROGRAMMING THE MACHINE	15
CLEANING THE SLICER	17
GENERAL	17
DISASSEMBLING THE MACHINE FOR CLEANING	17
CLEANING B 350 A	18
REASSEMBLING THE MACHINE	20
MAINTENANCE	20
GENERAL	20
BLADE SHARPENING	20
SHARPENING	21
LUBRICATION	25
TROUBLESHOOTING AND REMEDIES	26
DISMANTLING THE SLICER	27
ELECTRICAL DIAGRAM	28
RECOMMENDED SPARE PARTS	29

FOREWORD

SCOPE OF THIS MANUAL

This manual contains all the necessary information to install, use and service the gravity slicers for food (please see models in paragraph “Technical Description”). The scope of this document, hereinafter the “manual”, is to permit users, and especially end users, to take all the cautions and provisions possible for using this machine safely and for a long time.

GENERAL SAFETY REGULATIONS

The slicers must only be used by, suitably trained personnel. Furthermore, they must have read this manual carefully.

In particular, please comply to the following instructions

- Install the machine according to the instructions contained in the “Installation” section.
- Do not remove the transparent protections, do not modify nor exclude the mechanical and electrical safety devices.
- Do not use the machine with improvised connections, or provisional or non - insulated cables.
- Check the power cable and gland plate on the machine body regularly, and when necessary have them replaced by a qualified personnel.
- In case of abnormalities, defective operation, incorrect movement, unusual noise, etc stop the machine immediately.
- Before cleaning or servicing, disconnect the machine from the mains.
- Always use scratch proof and non-slip gloves during cleaning or maintenance.
- Lay or remove the goods to be sliced on the sliding plate only when the latter is completely pushed back and the thickness control knob is positioned to 0.
- To move the carriage tray when slicing, use the handle or the product grip handle.
- For extraordinary maintenance (to replace the sharpener wheels, the blade, or others) please contact the manufacturer or qualified and duly authorized personnel.
- Avoid running the slicers with no product on it
- The slicers are equipped with a ventilated motor
- WARRANTY: 1 YEAR except for the electrical parts

MANUFACTURER'S WARRANTY AND LIABILITY

The manufacturer's warranty covering the functioning of the machines and their compliance to the service for which they have been designed depends on the correct application of the instructions contained in this manual.

The Manufacturer assumes no liability either direct or indirect deriving from:

- Failure to comply with the instructions contained in this manual;
- Use of the machine by personnel who has not read or fully understood the content of this manual
- Use not complying to the specific norms currently applicable in the country of installation
- Unauthorized modifications and/or repairs
- Use of non original accessories or spare parts.
- Exceptional events.

PLATES – CONFORMITY MARKS

The machines have been constructed in compliance with the European Directive 89/392 and subsequent amendments. All the parts used in the machine meet the terms of the Directive and the CE marks have been applied to substantiate this compliance.

The plate carrying the Manufacturer's data, the machine data and the CE mark are applied onto the machine base under the blade guard tie-rod knob.

In case of wear or damage, the user must replace it.



ENVIRONMENTAL CONDITIONS OF USE

- Temperature from -5 °C to + 40 °C
- Relative humidity max 95%

PACKING

OPENING THE BOX

On receipt, check packaging integrity, otherwise inform the forwarding agent or the area agent immediately.

To unpack the machine, proceed as follows:

- Open the box and remove your copy of the manual of use and maintenance, then proceed according to the instructions found in that manual;
- Lift the machine still wrapped in a transparent polyethylene sheet and extract it from the box
- Now check the box contents and make sure it corresponds to what is shown on the external label.

WARNING:

The packaging components (cardboard, polyethylene, and others) are classified as normal solid urban waste and can therefore be disposed of without difficulty. In any case, for suitable recycling, we suggest disposing of the products separately (differentiated waste) according to the current norms.

DO NOT DISCARD ANY PACKAGING MATERIALS IN THE ENVIRONMENT!

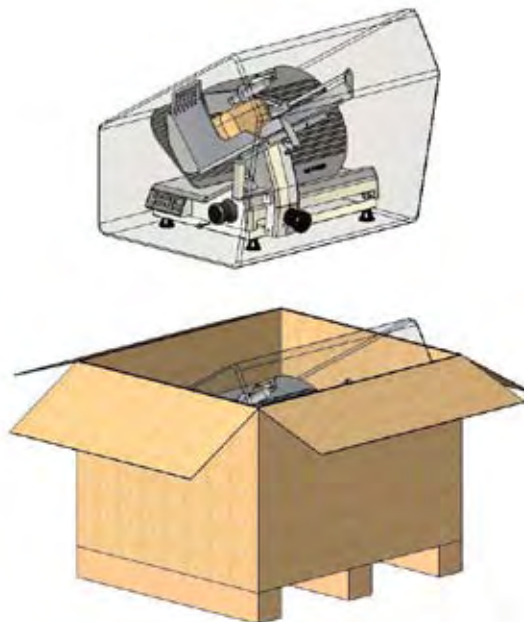

TECHNICAL DESCRIPTION AND PROPOSED CONDITIONS OF USE

GENERAL DESCRIPTION

The machine is essentially made of a base supporting a circular blade mounted in tilted position. This blade is driven by an electrical motor to slice food. The machine is equipped with a carriage holding a product tray and sliding on tracks mounted under the base top, parallel to the blade.

Slice thickness is adjusted by means of a gauge plate mounted in front of the blade. This plate, against which rests the product to be sliced is moved transversally with respect to the blade by a value corresponding to the desired slice thickness. The product is fed to the machine (towards the gauge plate) by gravity.

All the machine components are made of polished and anodized oxidized aluminum alloy, of stainless steel and food grade plastic material.

The blade is driven by an electrical motor, transmission is by means of a longitudinally grooved belt.

The machine is started and stopped by a control button provided with auxiliary circuit preventing accidental restarts after an outage.

Some of the machine models have a user-friendly and safe built-in blade sharpener.

MECHANICAL AND ELECTRICAL SAFETY DEVICES

The following mechanical safety devices were installed:

- A series of aluminum and transparent plastic guards on the product carriage.

The following electrical safety devices were installed:

- Start/stop button system requiring a voluntary restart of the machine in the case of an outage or interruption of the power supply.
- Safety micro-switch preventing the motor from starting when the blade guard is removed (not on the CE VERSION).

PRODUCTS THAT CAN BE SLICED

- All types of cold cuts (raw, cooked, smoked);
- Meat without bone (raw or cooked, at a temperature not less than + 3 °C);
- Cheese cuts (obviously types that can be sliced such as gruyere, fontina, etc.).

PRODUCTS THAT MUST NOT BE SLICED:

- Frozen or deep-frozen food
- Food containing bones (meat or fish)
- Any other non-food product



WARNING: RESIDUAL RISKS

Not with standing all the possible cautions taken during the design and the construction of the machine, residual risks (cutting) still exist during use or during cleaning or maintenance. Therefore be careful and PAY THE UTMOST ATTENTION to what you are doing.

DO NOT use the machine if you are not in perfect psychological and physical conditions. DO NOT ALLOW anyone near the machine when it is in use. ALWAYS wear gloves that can resist cuts or tears when cleaning, lubricating or sharpening the blade.

Slice only the products mentioned as sliceable. NEVER try to slice products that have been mentioned as non sliceable.



DIMENSIONS MAIN TECHNICAL DATA

AUTOMATIC GRAVITY SLICERS

MODEL	B 350 A		MODEL
motor Kw	0,35		motor Kw
blade diam	14"	350	blade diam
rpm	200		rpm
slice thicness	0 - 1"	0 - 25	slice thicness
max cut O	10"	250	max cut mm O
max cut <input type="checkbox"/>	12,5"x9"	320x230	max cut mm <input type="checkbox"/>
Cutting Speed			
Speed Min	48 with min stroke		
	56 with medium stroke		
	60 with large stroke		
Speed Medium	40 with min stroke		
	45 with medium stroke		
	50 with large stroke		
Speed Max	38 with min stroke		
	45 with medium stroke		
	50 with large stroke		
Overall dimensions			Overall dimensions - mm
lenght	18"	460	lenght
width	25,5"	650	width
height	18"	455	height
gross weight - Lbs	121 Lbs	55	gross weight - Kg
net weight - Lbs	106 Lbs	48	net weight - Kg
box dimensions	28"x32,5"x24,5"	710x830x850	box dimensions mm

MAIN COMPONENTS gravity version

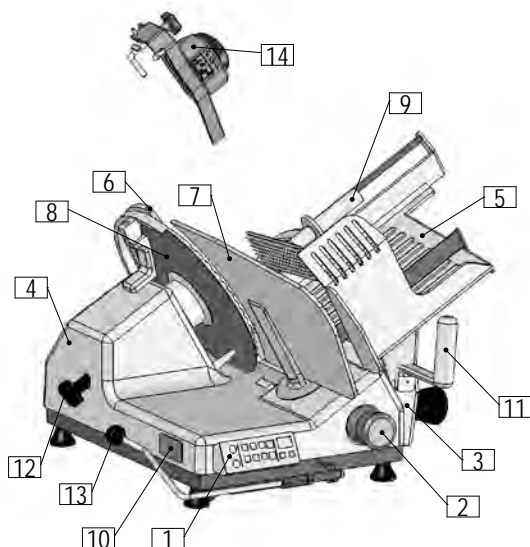

CODE	DESCRIPTION
1	CONTROL PANEL
2	THICKNESS KNOB
3	CARRIAGE SUPPORT
4	FRAME
5	CARRIAGE
6	BLADE GUARD
7	GAUGE PLATE
8	BLADE
9	PUSHER HANDLE
10	MANUFACTURER IDENTIFICATION PLATE
	MACHINE DATA AND UE MARKS
11	CARRIAGE HANDLE
12	BLADE GUARD ROD
13	LIFT/CLEANING HANDLE
14	SHARPENER

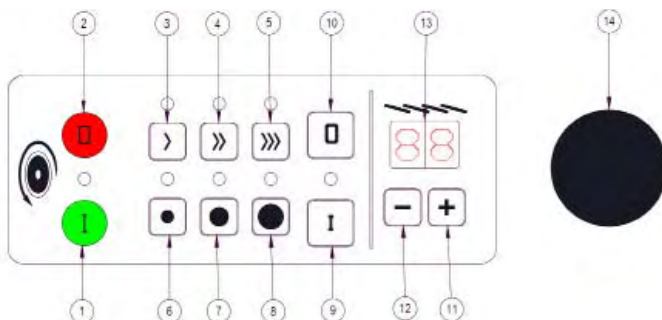

CONTROL PANEL							
1	START SWITCH						
2	STOP SWITCH						
3	SPEED MIN	48	with min stroke	40	with medium stroke	38	with large stroke
4	SPEED MEDIUM	56	with min stroke	45	with medium stroke	45	with large stroke
5	SPEED MAX	60	with min stroke	50	with medium stroke	50	with large stroke
6	STROKE	150 mm					
7	STROKE	250 mm					
8	STROKE	350 mm					
9	AUTO CARRIAGE START						
10	AUTO CARRIAGE STOP						
11	COUNTER +						
12	COUNTER -						
13	COUNTER DISPLAY						
14	AUTOMATIC START/STOP MECHANISM						

MACHINE COMMISSIONING AND FUNCTION TESTS

INSTALLING THE MACHINE

Position the machine on a well leveled, smooth and dry top suitably dimensioned to withstand the machine weight.

ELECTRICAL CONNECTION

Install the machine near a compliant outlet derived from a system meeting the current norms.

The user is responsible for ascertaining that the electrical system is suitably dimensioned and functions correctly (supply line, outlet, distribution panel, differential protecting breaker, grounding).

Before carrying out the connection ascertain that the mains characteristics correspond to those indicated on the machine plate.

COMMANDS

START AND STOP BUTTONS

- Press the green button (1) to start running the blade.
- The light turns on to indicate that the machine works correctly.
- Press the red button to stop the blade (2).

Slice thickness can be adjusted by turning the graduated knob (3) anti clockwise.

Thickness adjustment range: see paragraph "Technical description and conditions of use".

FUNCTIONING TEST AND BLADE ROTATION DIRECTION

Start the machine and check whether the light is on; make sure that the blade rotates in the direction indicated by the arrow (anti clockwise if you look at the machine from the blade plate side).

- Ascertain that the carriage and the pusher slide correctly;
- Ascertain that the gauge plate works and adjust thickness to desired value.

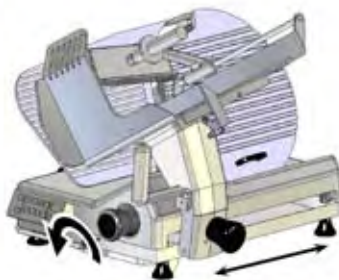
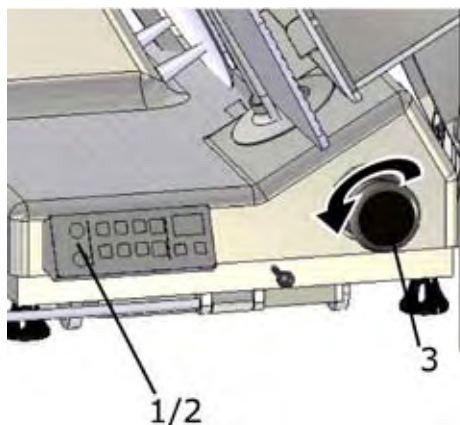

USING THE MACHINE

LOADING THE PRODUCT ON THE TRAY AND SLICING

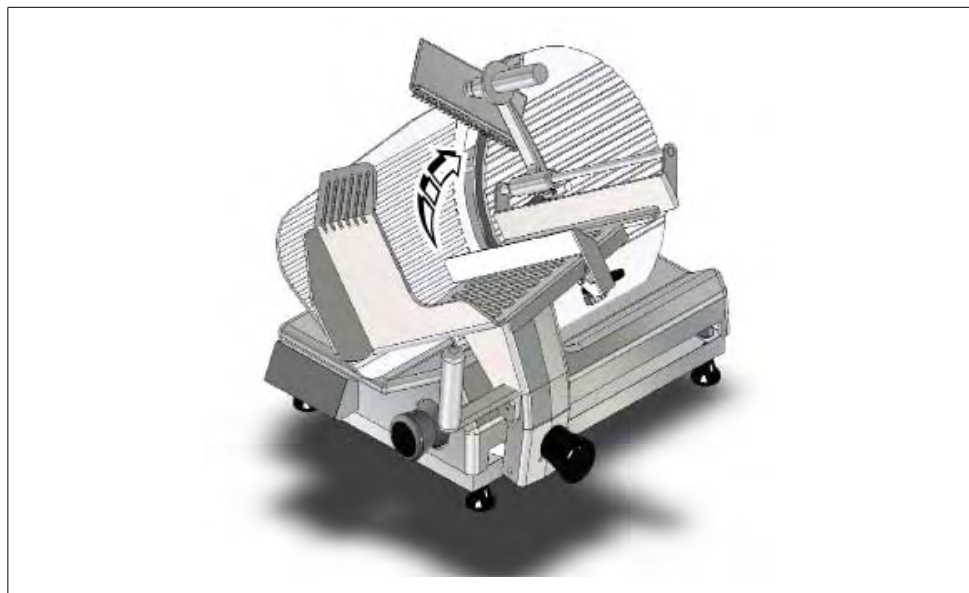

Lift the gripper arm

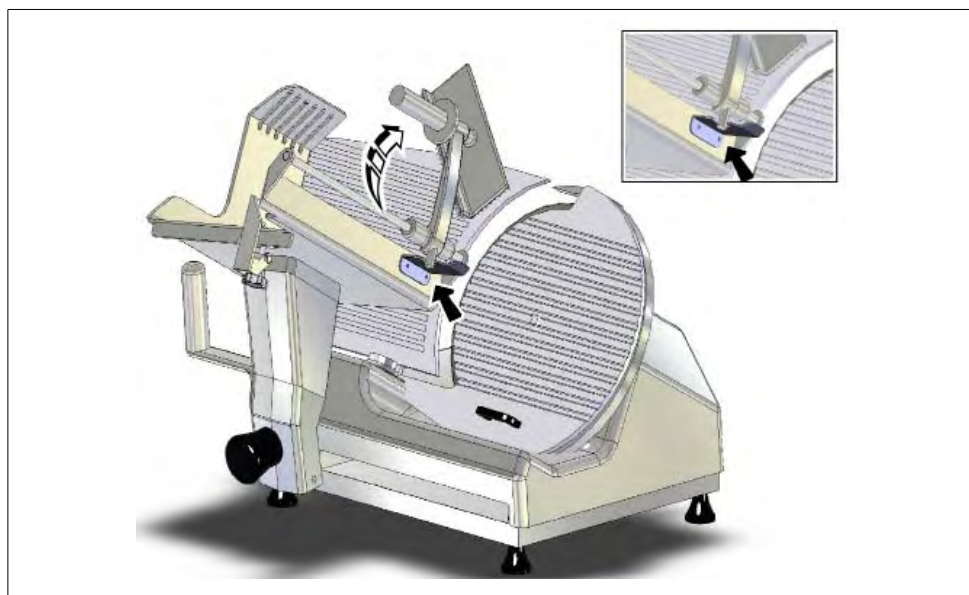

Lock the gripper arm into the rest position as shown in photo B

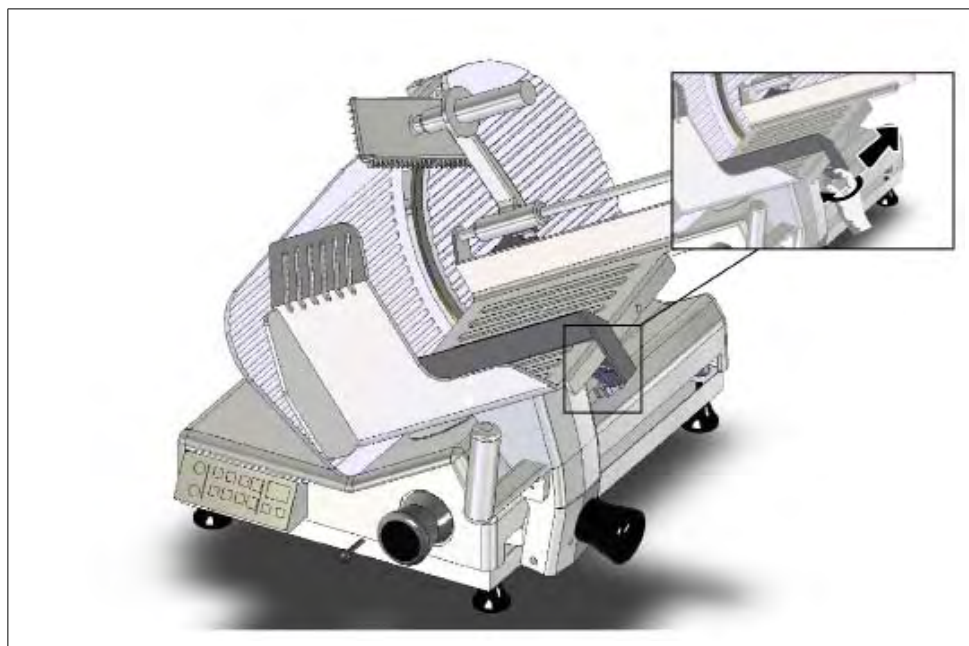

Unscrew the fence retaining knob and slide the fence in to the outer position

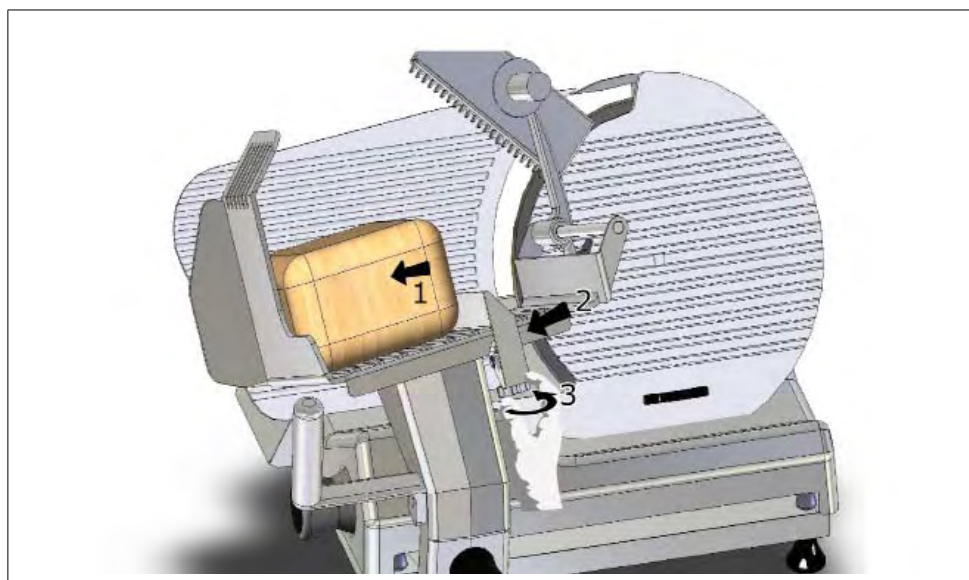

1. Load the product on to the meat platform
2. Slide the fence against the product
3. Lock the fence in place firmly using the locking knob

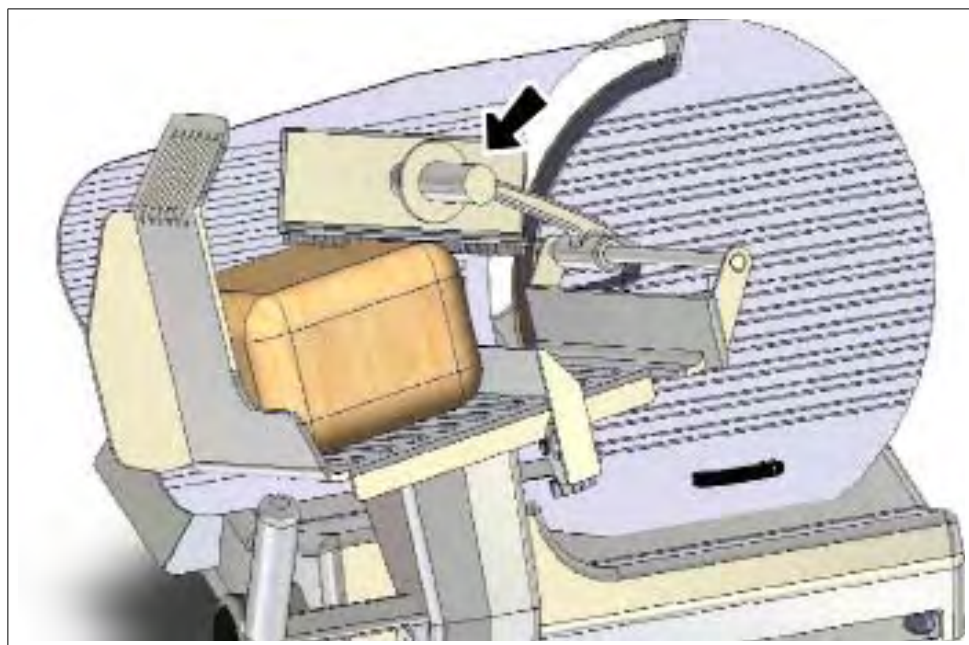

Locate the gripper arm onto the product

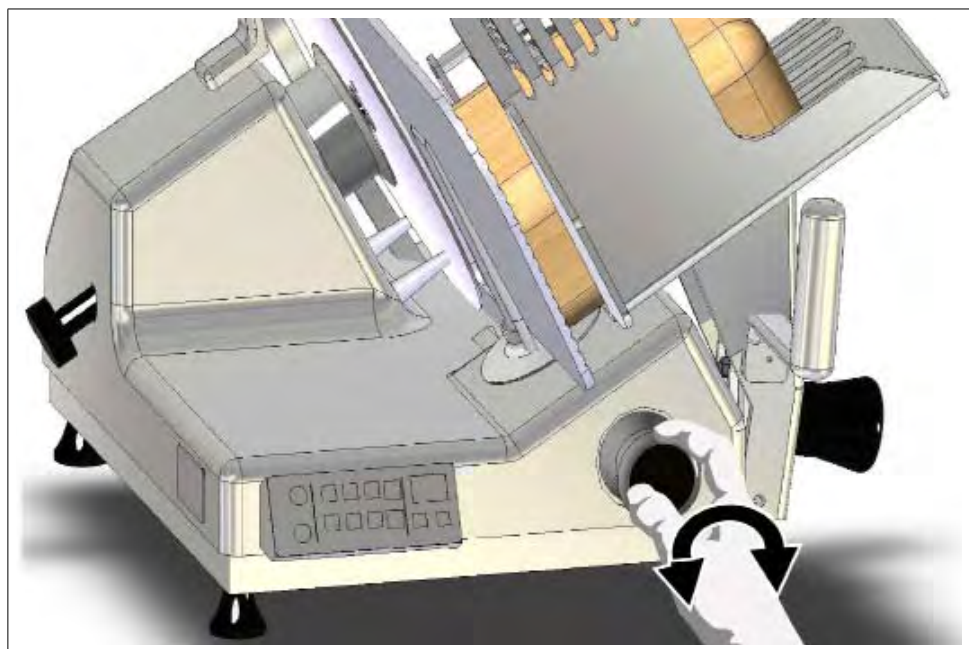

Select the thickness of the product to be sliced using the portion thickness control knob

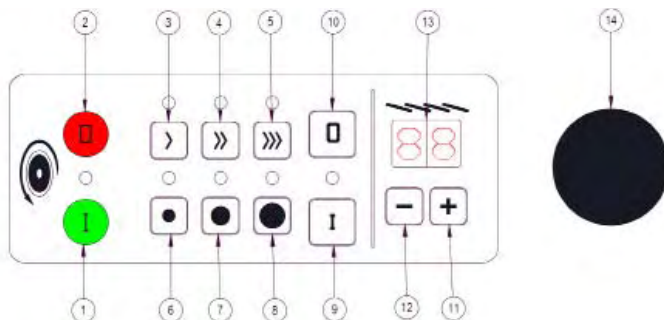

CONTROL PANEL

1	START SWITCH						
2	STOP SWITCH						
3	SPEED MIN	48	with min stroke	40	with medium stroke	38	with large stroke
4	SPEED MEDIUM	56	with min stroke	45	with medium stroke	45	with large stroke
5	SPEED MAX	60	with min stroke	50	with medium stroke	50	with large stroke
6	STROKE	150 mm					
7	STROKE	250 mm					
8	STROKE	350 mm					
9	AUTO CARRIAGE START						
10	AUTO CARRIAGE STOP						
11	COUNTER +						
12	COUNTER -						
13	COUNTER DISPLAY						
14	AUTOMATIC START/STOP MECHANISM						

Control panel

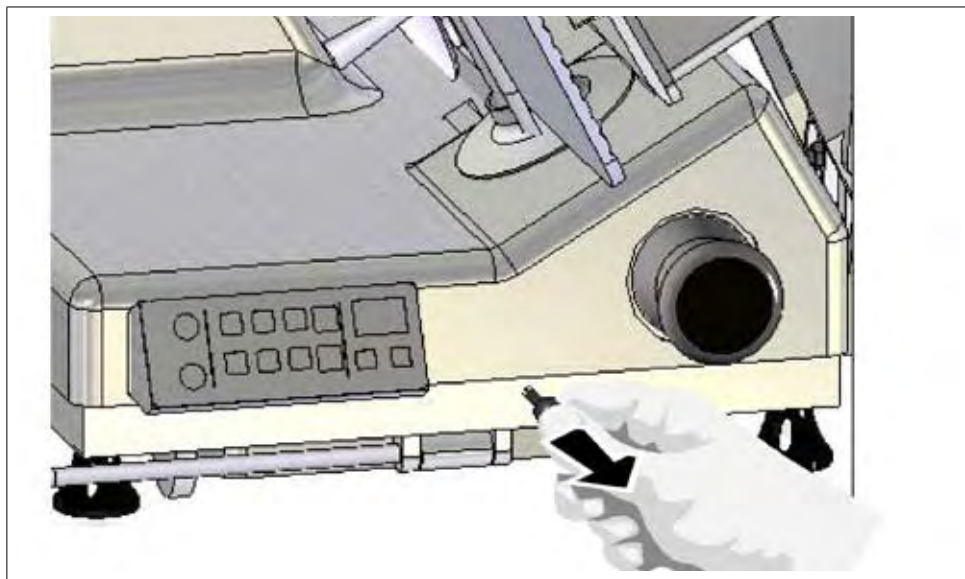

To activate the automatic slicing action pull the knob located at the front of the machine towards you. If manual slicing is required push the knob in toward the machine.



If the automatic slicing action is not connected, ALARM 01 will flash.

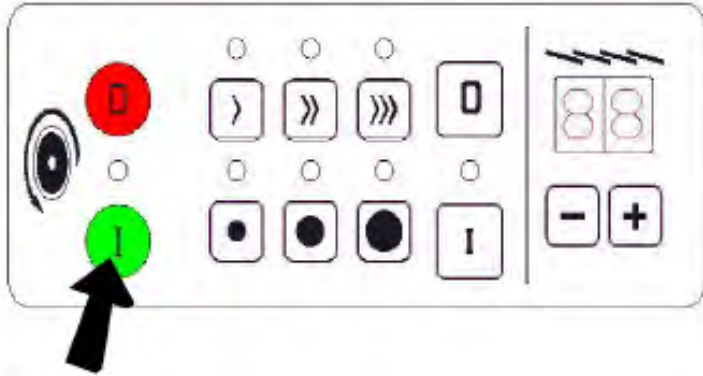

Push the green button to start the machine running

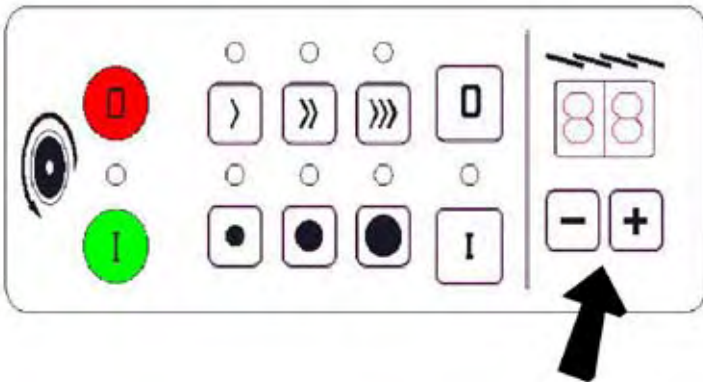

Programming the machine:

1. The machine can be programmed to slice a set number of slices automatically and then stop

- a) If the display shows 00 the machine will continuously run until stopped by the operator
- b) Set the display e.g. 12 on the counter using the + key, the machine will then slice 12 portions and then stop.

Speed & Stroke Programming:

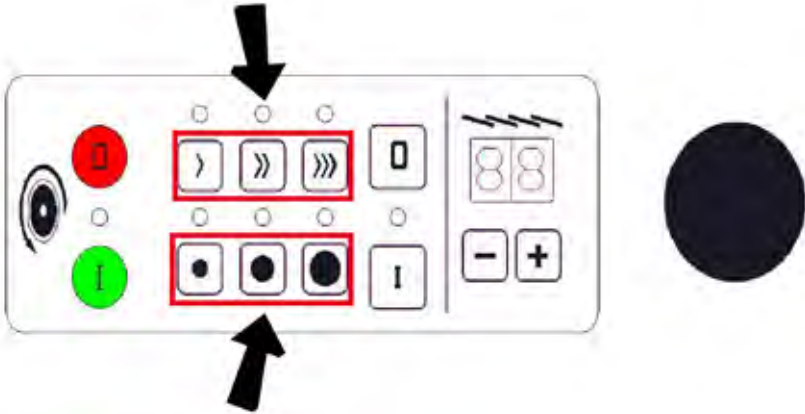

Speed:

There are 3 speed settings on the machine using the > key, select > >> or >>> to increase or decrease the speed

Stroke: Dependent on the size of the product that is to be sliced, the machine can be programmed more efficiently using the stroke keys e.g. The small black circle is ideal for salami and sausage type products etc The medium black circle is ideal for cheese etc The large black circle is ideal for full hams, beef etc

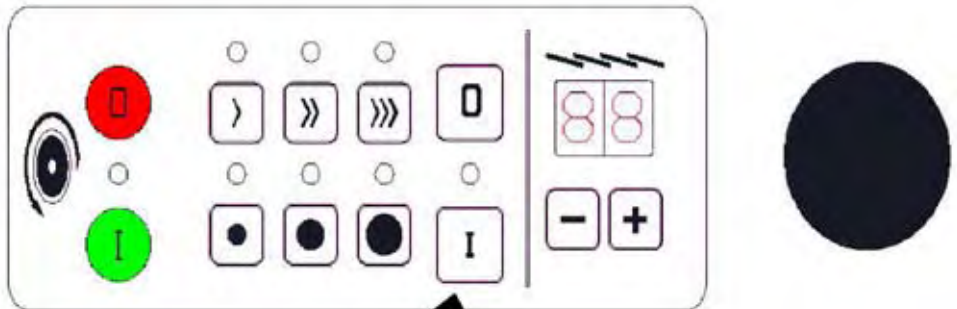

> SPEED MIN

>> SPEED MEDIUM

>>> SPEED MAX

● STROKE MIN

● STROKE MEDIUM

● STROKE LARGE

Press the 1 key to operate the machine in the programme that is set

CLEANING THE SLICER

GENERAL

The machine must always be accurately cleaned at least once a day, and more often if necessary.

Always use protective gloves.

DISASSEMBLING THE MACHINE FOR CLEANING

- Disconnect the plug from the mains;
- Turn the gauge plate to '0';
- Remove the various components as described in the following paragraphs:
- Unscrew (anticlockwise) the blade guard rod (ref. 1);
- Remove the blade guard using for this operation only cover handle (ref. 2).
- Remove the slice guard.

To clean the machine body and the blade use only a cloth dampened with water and biodegradable lathery detergent having 7-8 pH and at a temperature not below + 30°C.

Do not clean the machine by using water or vapor spruïys or similar systems.

WARNING:



Use scratch-proof and non-slip gloves to carry out the following operations.
Proceed carefully and pay attention to what you are doing.
Danger of cutting!

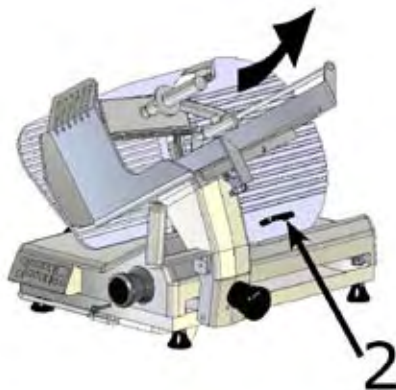

CLEANING THE SLICER UNI 350 G-A (2: UP SETTING PLATE)

- Stop the machine, rotate the adjustable knob to regulate the gauge plate and position it on 0 (1)
- Return the carriage to the operators side (2)
- Turn the knob (3) anti clockwise, until loose, the carriage will then drop back for cleaning (4).

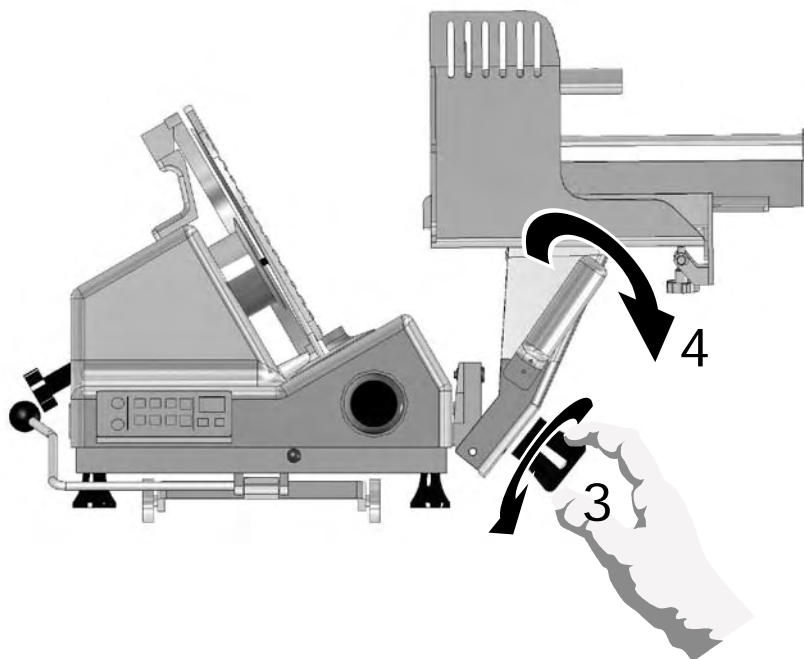
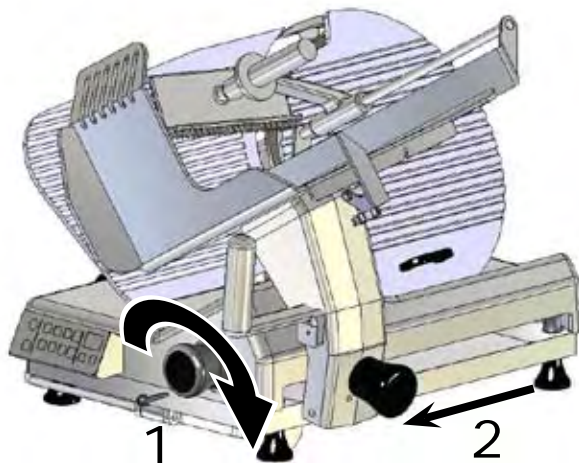

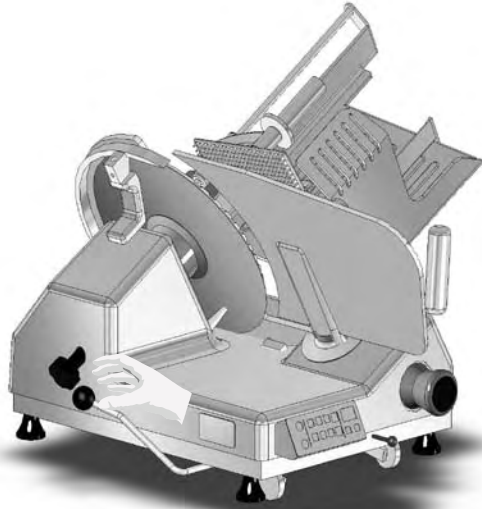

(1) Hold the Lever

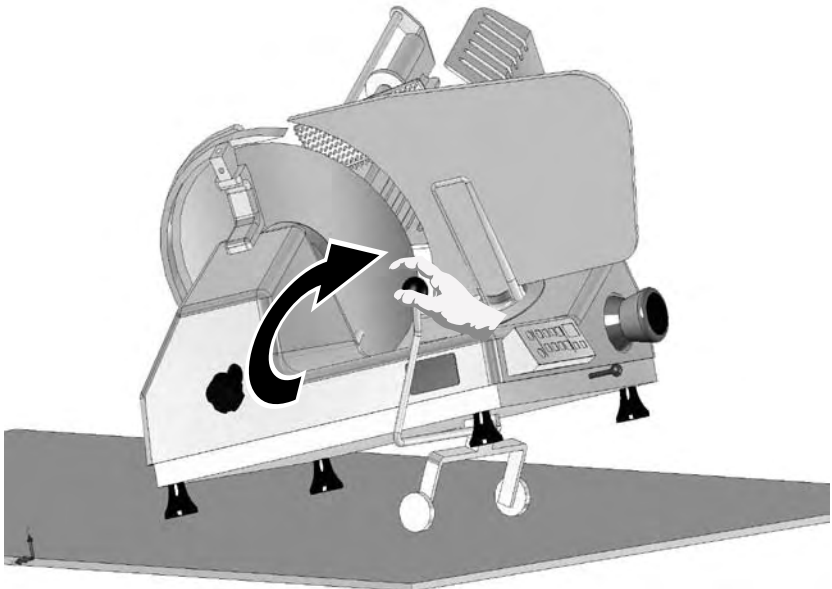

(2) Lift the Machine

REASSEMBLING THE MACHINE

Proceed as indicated for the previous operations but in reverse order.

MAINTENANCE

GENERAL

The operator is allowed to perform the following maintenance operations:

- Blade sharpening: regularly (intervals and duration obviously depend on the use of the machine, time of use and type of product sliced);
- Lubrication of product grip sliding bar: once a week.
- Checking the power supply cord conditions and the gland plate: from time to time.

WARNING



Maintenance must always be carried out when the machine is disconnected from the mains.

Always make sure that the adjustable knob is in the “O” position

The following maintenance operations are to be entrusted only to **personnel authorized by the manufacturer**:

- **Replacing the blade;**
- **Replacing the sharpener stones;**
- **Replacing the motor transmission belt;**
- **Replacing electrical system components under the machine base;**
- **Repairing structural parts, repairing the components under the base.**

BLADE SHARPENING

Before proceeding, clean the machine accurately as explained in the previous paragraphs:

WARNING



Sharpening can be done only up to 12 mm of the blade diameter value.

Beyond this value, the BLADE MUST BE REPLACED ONLY by personnel AUTHORIZED BY THE MANUFACTURER.

SHARPENING B 350 A

Versions with separated sharpener

To sharpen the blade periodically as soon as the cutting capacity decreases. Please proceed as per the following instructions:

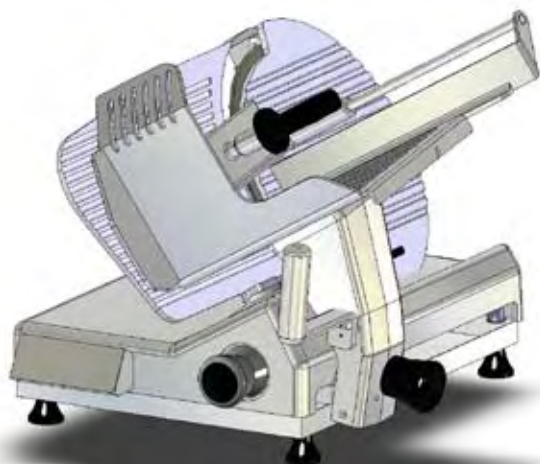

1) CLEAN THE BLADE

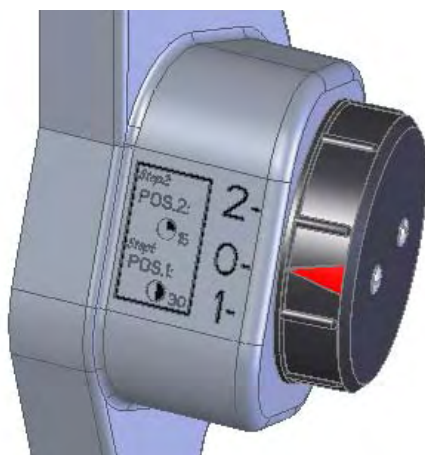

2) ASSURE THE SHARPENER IS AT ZERO POSITION

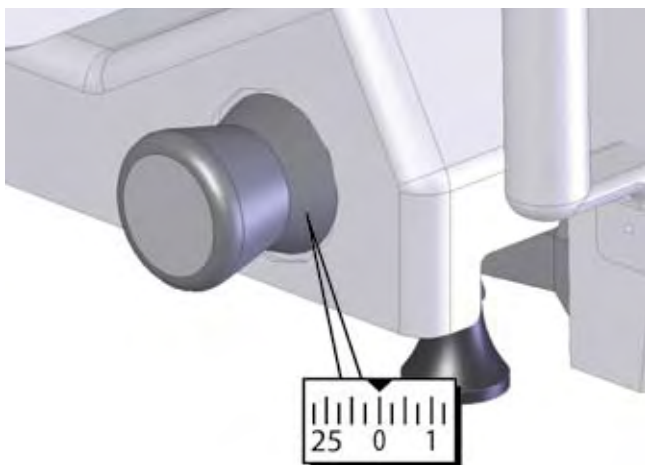

- 3) MOVE THICKNESS REGULATOR TO THE 25mm POSITION
ONCE THE GAUGE PLATE IS OPENED AT MAX POSITION, THE AUTOMATIC
MOVEMENT DOESN'T RUN, IN ORDER TO PERMIT THE SHARPENING



002 ALARM WILL FLASH

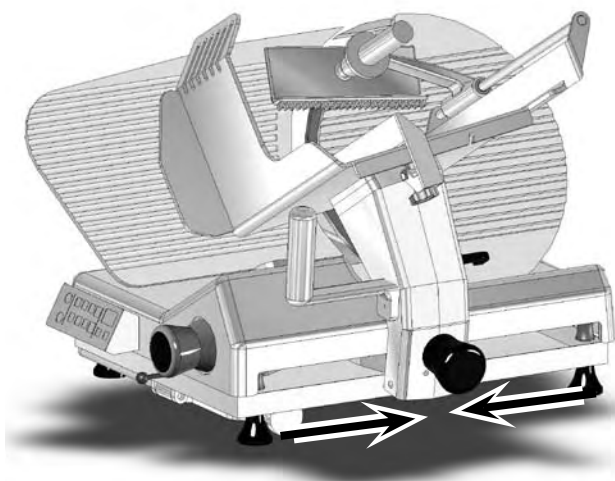

- 4) THIS OPENED THE BLADE TO THE DESIRED POSITION READY FOR POSITIONING
THE SHARPENER. MEAT PLATE POSITIONED IN THE MIDDLE.

5) THE SMALL RECESS ON THE GAUGE PLATE IS FOR THE POSITIONING OF THE SHARPENING MECHANISM.

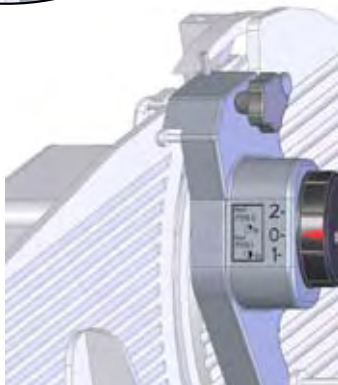
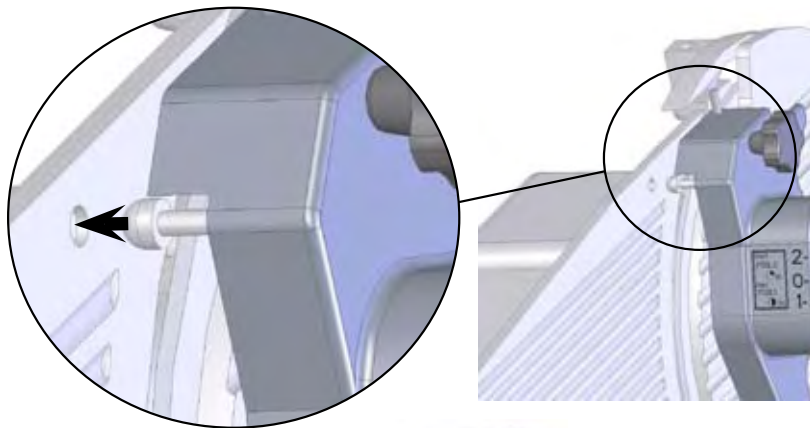

PLACE SHARPENING MECHANISM ONTO PLATE.

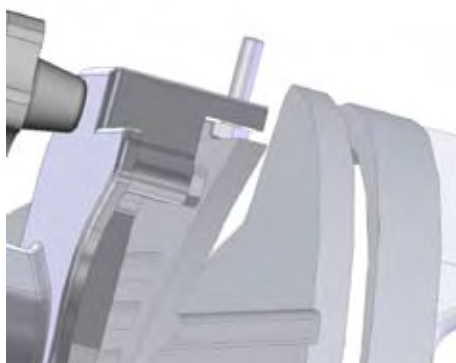

6) VERIFY POSITION

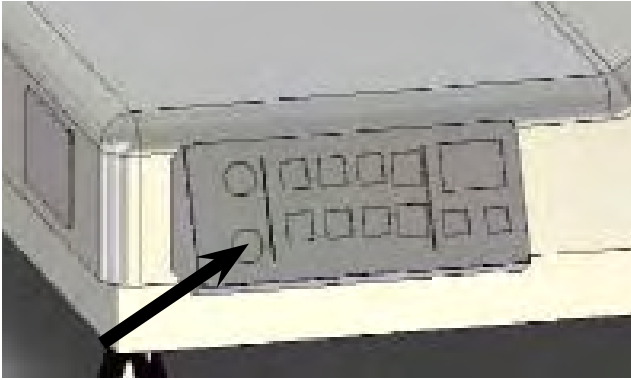

7) START BLADE ROTATING

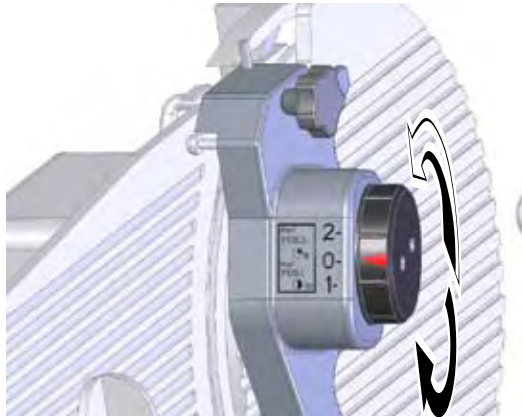

8) TURN DIAL TO POSITION 1. THIS WILL SHARPEN THE REAR OF THE BLADE.
RUN FOR 15 SECONDS, TURN DIAL TO POSITION 2 FOR 5 SECONDS. THIS WILL
TAKE THE BURR OF THE FRONT SURFACE OF BLADE

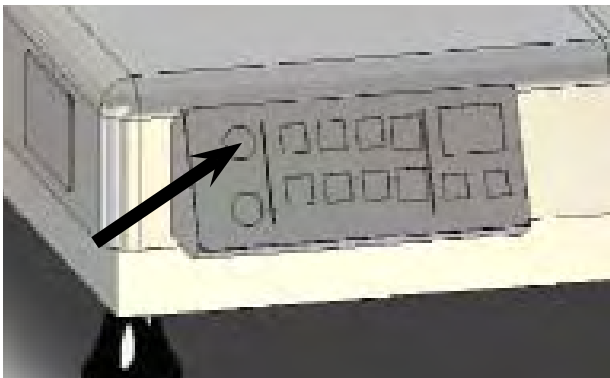

9) STOP MACHINE. REMOVE SHARPENER AND CLEAN BLADE BEFORE
USING THE MACHINE AGAIN.

LUBRICATION

Carriage sliding guides product grip (once a week)

**Use only the oil provided, otherwise use white Vaseline oil.
DO NOT USE VEGETABLE OILS.**

- Spread a small quantity of oil on the bar and move the assembly 3 or 4 times.
- Clean as required to remove excess of oil.

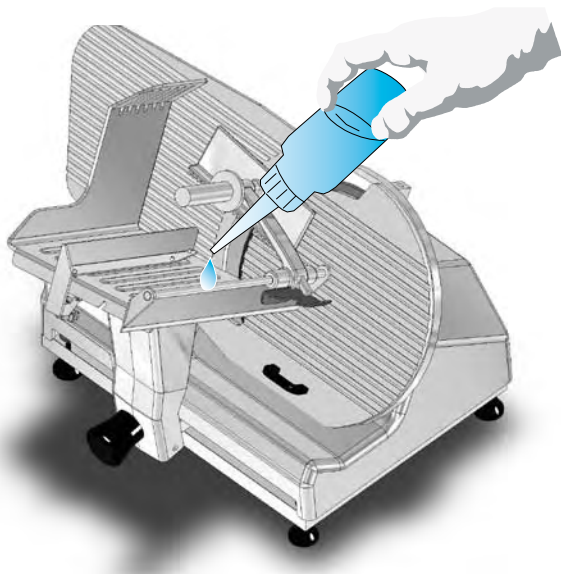

TROUBLESHOOTING AND REMEDIES

The table below indicates the most common problems that may arise during slicing and the necessary remedies.

PROBLEM	POSSIBLE CAUSE	REMEDY
The machine does not start when the green button is pressed	No power supply The blade guard is not correctly positioned. Defective electrical control circuit.	Ascertain that the plug is correctly inserted. Check Call technical assistance
The machine does not start, and there is continuous noise like a buzz (only in the case of machines equipped with three-phase motors).	The motor is running on single-phase mode	Press the red button immediately and have the power supply cord and the circuits upstream verified by qualified personnel.
ALARM 01	Automatic mechanism not connected	
ALARM 02	Once the gauge plate is opened at max position, the automatic movement doesn't run, in order to permit the sharpening	
When the green button is pressed, the machine starts, but the white functioning light is not on.	Defective indicator	Do not use the machine when the pilot lamp is not on. Call technical assistance
The machine starts, but there are vibrations. The motor is very hot and there is a bad smell.	Defective motor or transmission.	Do not use the machine. Call technical assistance.
Under strain, the machine slows down or comes to a stop.	Defective transmission	Call technical assistance
Excessive resistance to product slicing.	The blade is blunt	Sharpen the blade
The slices are ragged and/or shaped irregularly	The blade is blunt The blade is excessively worn out	Sharpen the blade Call technical assistance
Unsatisfactory blade sharpening	Worn wheels	Replace the wheels. Call technical assistance
The product tray does not slide	Guides are insufficiently lubricated	Lubricate
When the red button is pressed, the machine does not stop	Defective electrical control circuit	Stop the machine, unplug from mains and call technical assistance

DISMANTLING THE SLICER

These machines are made of the following elements:

- Aluminum frame;
- Stainless steel fittings and others;
- Electrical parts and cords;
- Electrical motor;
- Plastic materials, etc.

Whether dismantling is entrusted to third parties or done in-house (in that last case you will have to separate the various materials) please note that disposal of the materials can only be carried out by duly authorized businesses.

In any case, please comply to the current norms of your country.

WARNING



**In any case, to remove the blade and dispose of it, you must contact the manufacturer or personnel duly authorized by the manufacturer.
NEVER DISPOSE OF WASTE IN AREAS WHERE ACCESS IS NOT DELIMITED BY BARRIERS AND FORBIDDEN BY WARNING SIGNS AS THIS WASTE REPRESENTS A SERIOUS DANGER, ESPECIALLY FOR CHILDREN AND ANIMALS. ANY RESPONSIBILITY ARISING OUT OF INCORRECT DISPOSAL FALLS ON THE OWNER.**

ABM COMPANY
UNI 350 G AUTO
Automatic Slicer
Recommended Spare Parts

Z9MAF
Sharpening stone

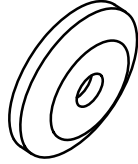

Z9PIE
Foot

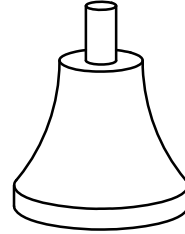

Z9MSB
Cleaning stone

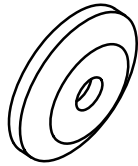

Z5L3G
Blade

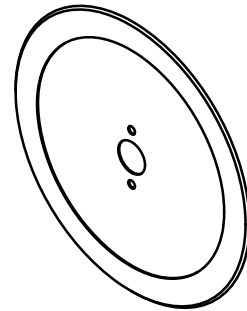

AF01US
Sharpening assembly

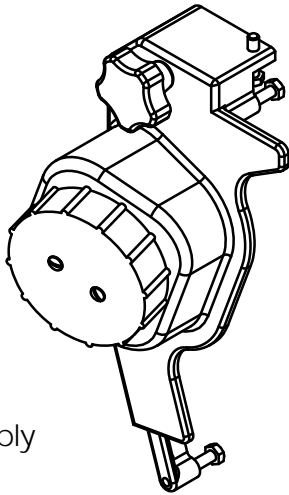

G111
Water-ring protection

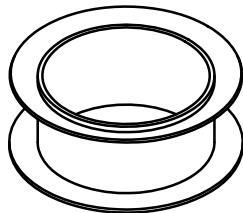

GG5CIN
Transmission Belt

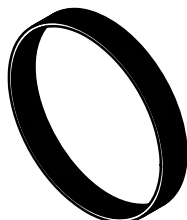

ABM COMPANY
UNI 350 G AUTO
Automatic Slicer

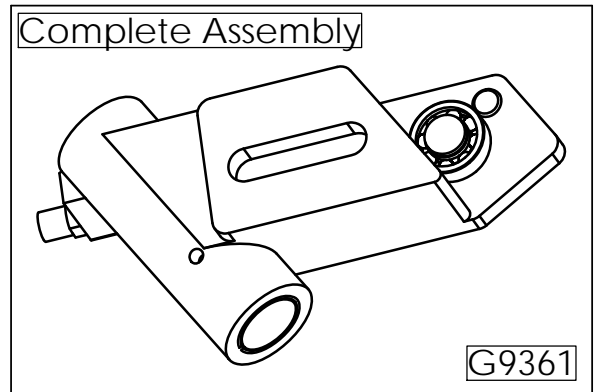
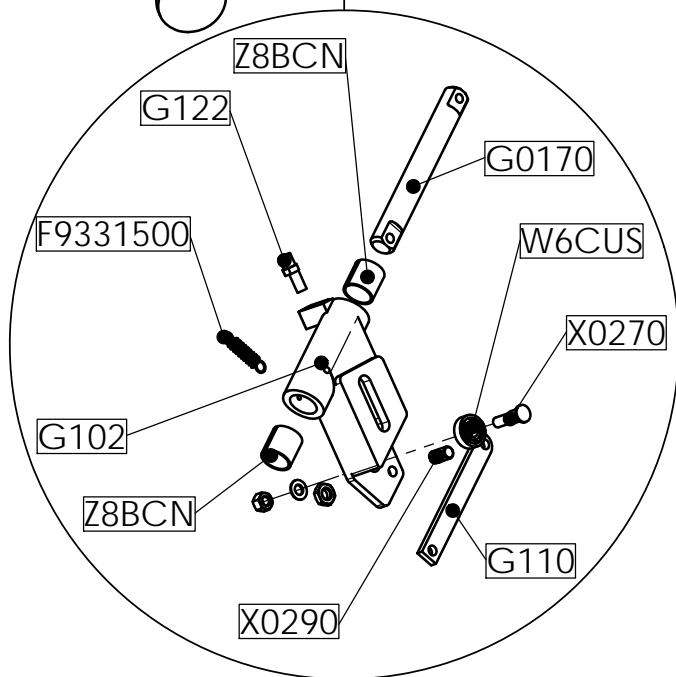
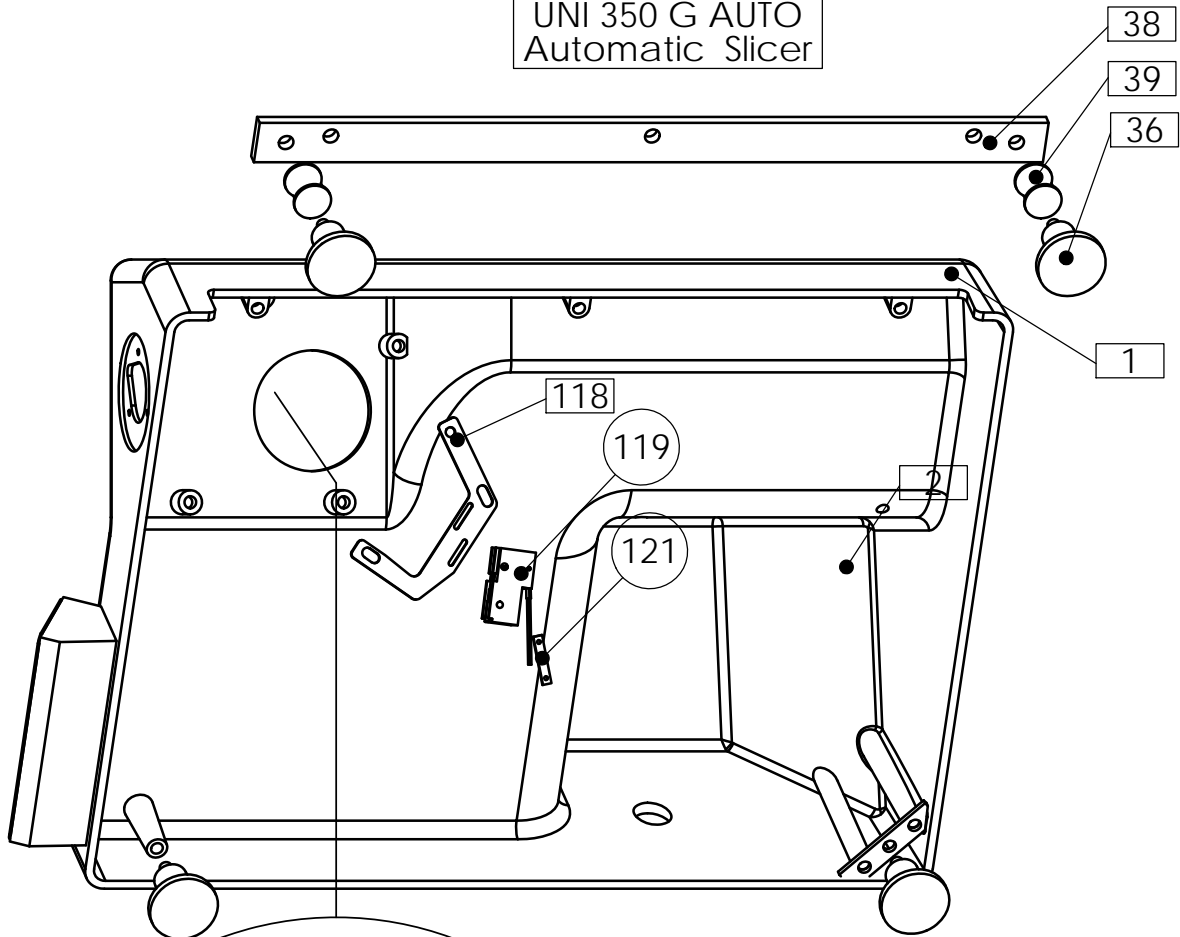

CODE	DESCRIPTION	Q,TY
F9331500	SPRING d 10 L 55	1
G0170	ROD - INDEX SLIDE	1
G102	SLIDE - INDEX MECHANISM	1
G110	ROD - INDEX ANTI ROTATION	1
G119C	SLIDE ROD - 25 x 578	1
G122	PIN - INDEX CAM	1
G9361	SLIDE INDEX COMPLETE ASSEMBLY	
W6CUS	SS BEARING 6000 ZZ 10 x 20 X 6	1
X0180C	SS BAR - TRANSPORT ROLLER	1
X0270	BEARING PING 10 x 30 M6	1
X0290	GUIDE - INDEX MECHANISM	1
X0560	SS FOOT SPACER 25 x 44 M8	2
Z8BCN	BUSHING 20 23 20E	2
Z9PIE	FOOT	4

ABM COMPANY
UNI 350 G AUTO
Automatic Slicer

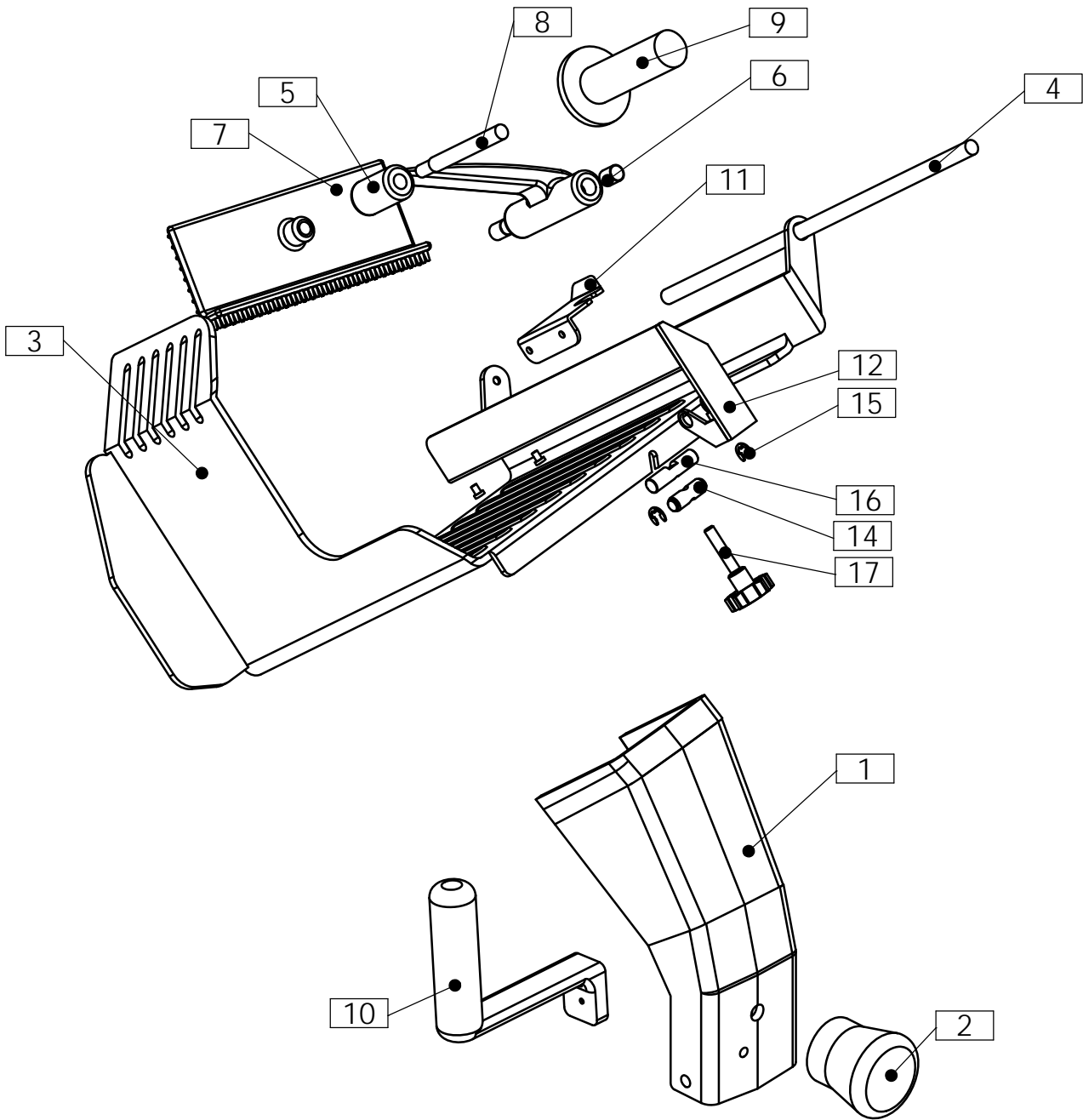

CODE	DESCRIPTION	Q,TY
C2032	MEAT GRIP HOLDER	1
C2041	MEAT GRIP	1
C2080	BUSHING	2
C2091	HANDLE ASSY	1
F9321500	KNOB - LOCKING FENCE ASSEMBLY	1
G0122	CARRIAGE TRAY	1
G0124	SLIDE ROD ASSY	1
G0160A	HANDLE	1
G103	SUPPORT - TRAY ASSY	1
G118	KNOB SHAFT	1
G127	FENCE SHAFT	1
G9362	FENCE ASSEMBLY	
X0360	ALU KNOB	1
G121	HANDLE - CARRIAGE	1
Z9MBP	KNOB - SUPPORT TRAY	1

ABM COMPANY
UNI 350 G AUTO
Automatic Slicer

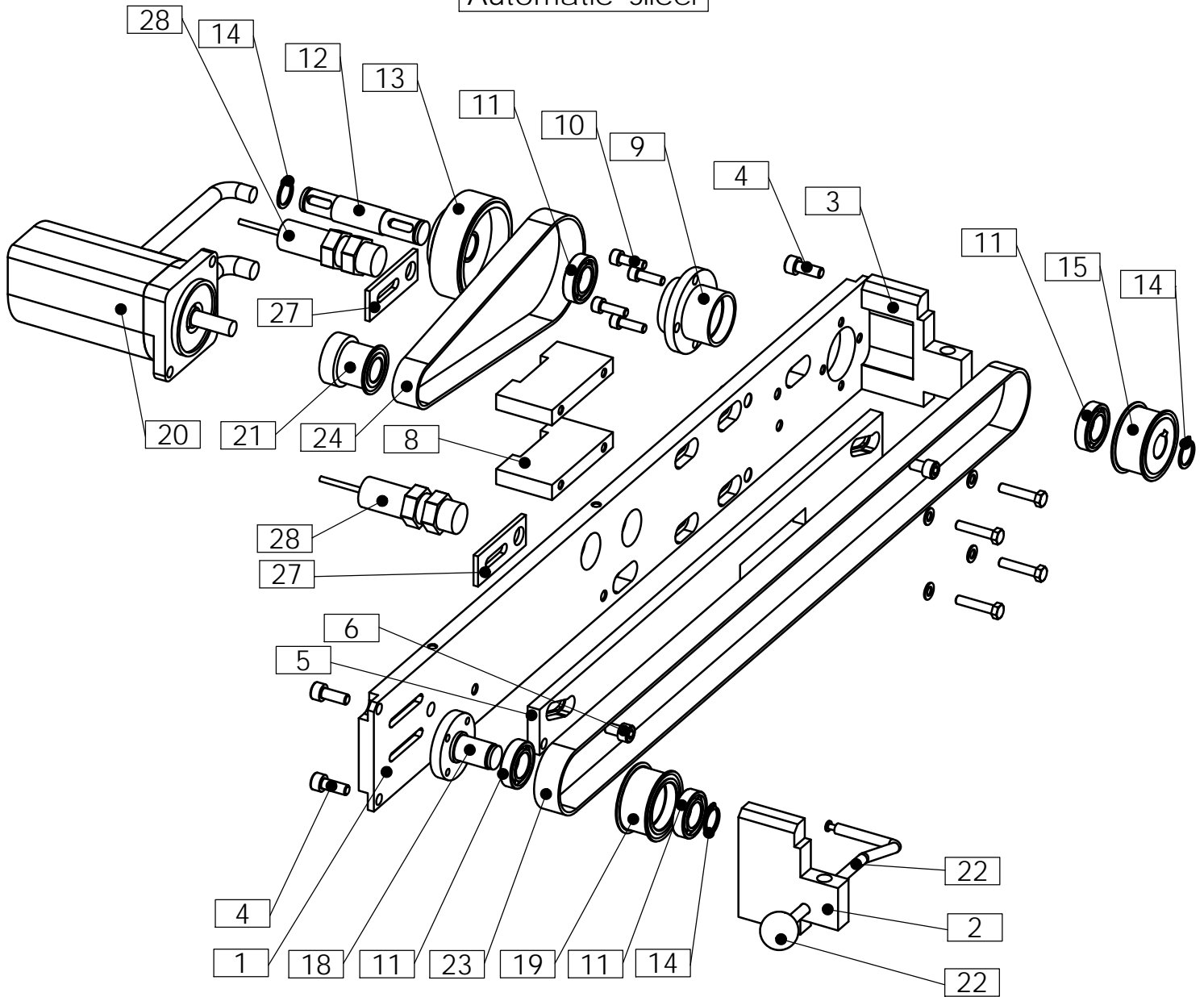

CODE	DESCRIPTION	Q,TY
C2032	MEAT GRIP HOLDER	1
C2041	MEAT GRIP	1
C2080	BUSHING	2
C2091	HANDLE ASSY	1
F9321500	KNOB - LOCKING FENCE ASSEMBLY	1
G0122	CARRIAGE TRAY	1
G0124	SLIDE ROD ASSY	1
G0160A	HANDLE	1
G103	SUPPORT - TRAY ASSY	1
G118	KNOB SHAFT	1
G127	FENCE SHAFT	1
G9362	FENCE ASSEMBLY	
X0360	ALU KNOB	1
G121	HANDLE - CARRIAGE	1
Z9MBP	KNOB - SUPPORT TRAY	1

ABM COMPANY
UNI 350 G AUTO
Automatic Slicer

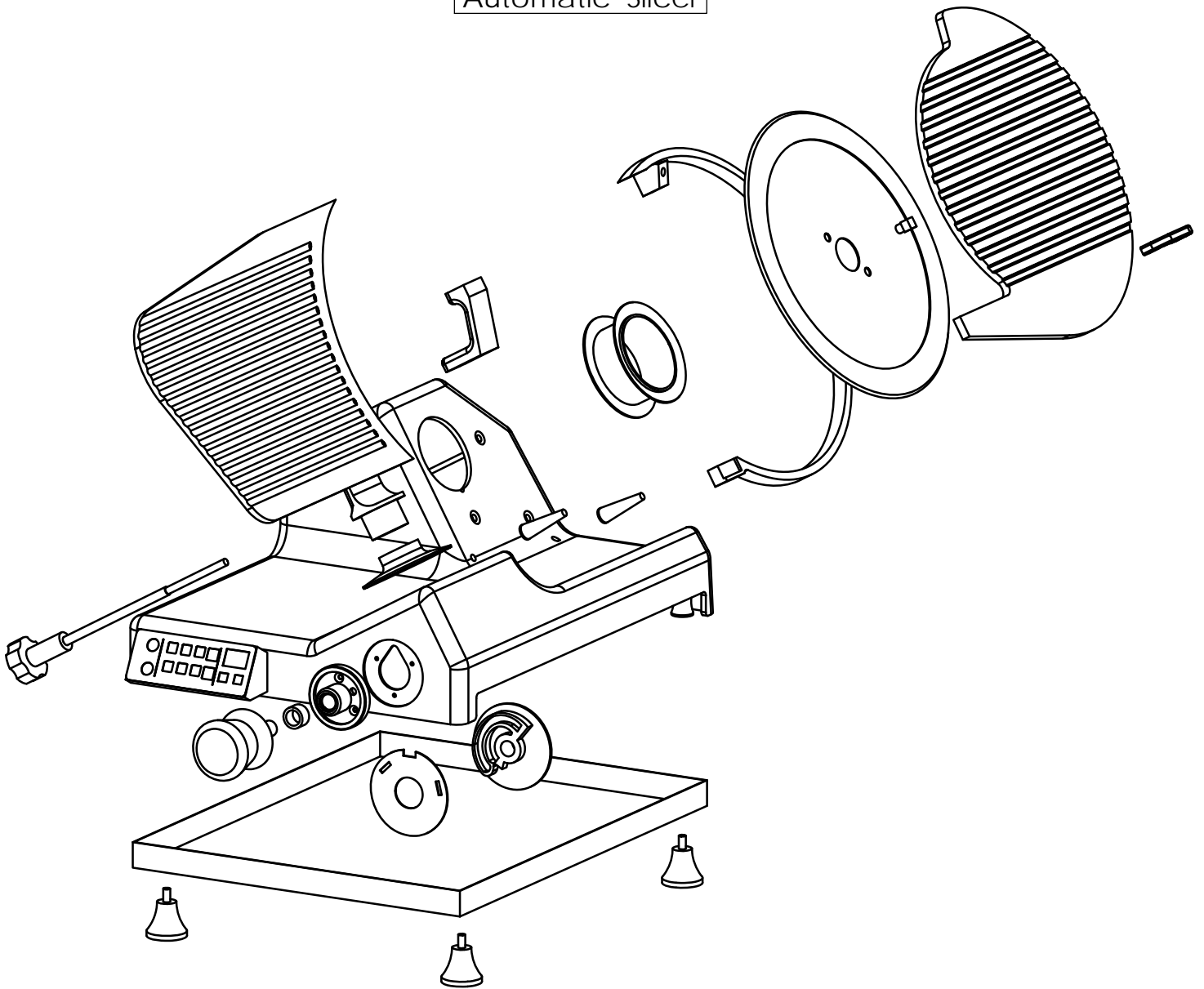

CODE	DESCRIPTION	Q.TY
G100	FRAME	1
G101	GAUGE PLATE	1
G105B	RING STUDBOLT	1
G111	WATER RING PROTECTION	1
G112	RING - GAUGE PLATE	1
G117	SPACER - PROTECTION RING	2
G120	KNIFE RING	1
G124	CAM - INEXING 25 mm	1
G125	BLADE GUARD ROD	1
G9364	BLADE GUARD ROD - ASSEMBLY	
X0080	SPACER - CAM	1
X0280	BUSHING	1
X0360	KNIFE GUARD	1
X0491	HANDLE - COVER BLADE	1
Z3ATQ	KNIFE GUARD LOCKING SCREW	1
Z5L4G	KNIFE 350 mm 14"	1
Z8MGR	KNOB - INEXING	1
Z9GHI	KNOB SPACER	1
ZZVOL	KNOB - BLADE GUARD ROD	1

ABM COMPANY
UNI 350 G AUTO
Automatic Slicer

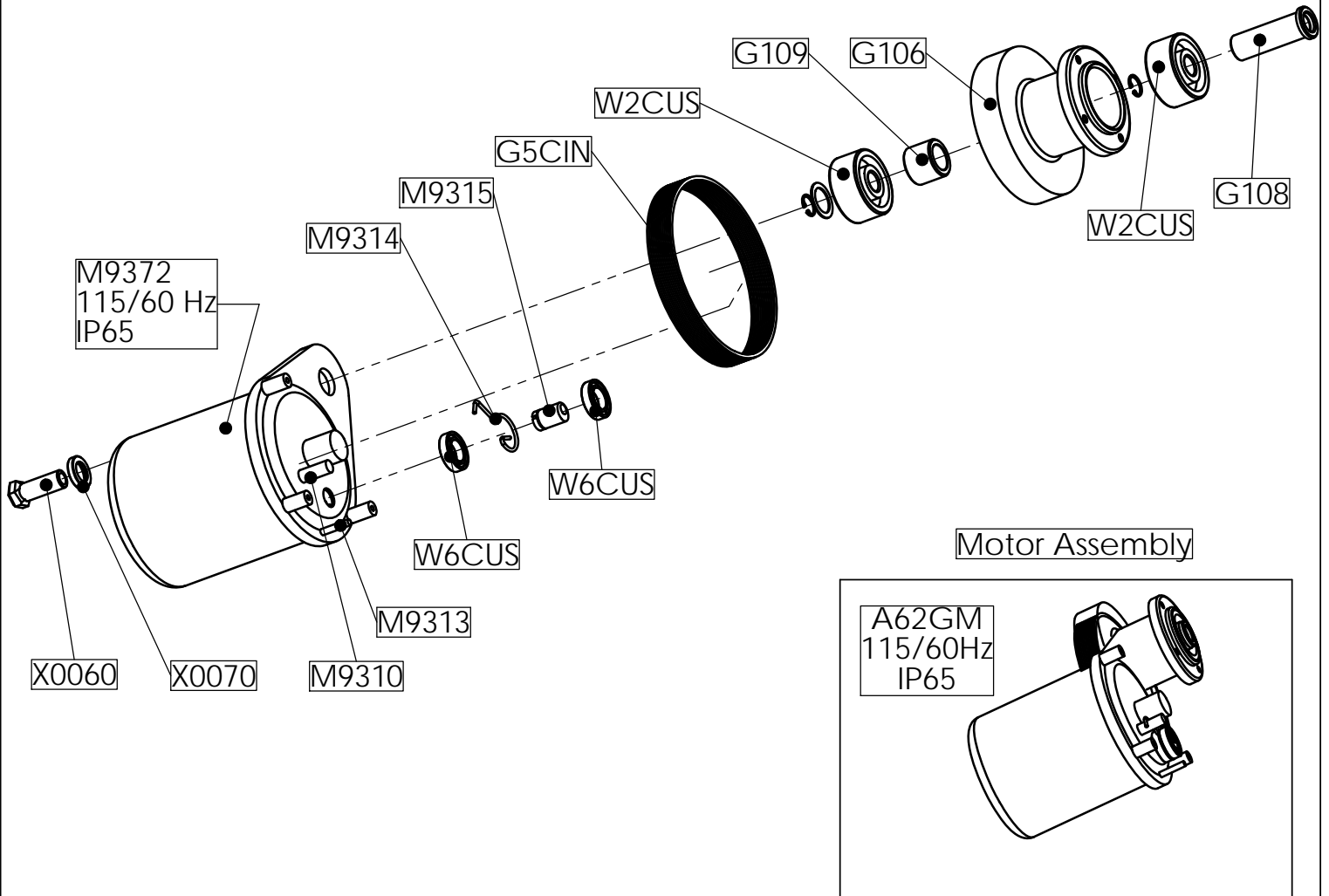

CODE	DESCRIPTION	Q.TY
A62GM	MOTOR ASSEMBLY IP 65	
G106	PULLEY B 350 M	1
G108	SHAFT - KNIFE 25 x 97	1
G109	SPACER	1
G5CIN	BELT 2350/2370 G TB2 11 x 400	1
M9310	PIN 10 x 22	1
M9313	SPRING PIN 5 x 25	1
M9314	BEARING TENS. SPRING	1
M9315	BEARING PIN	1
M9372	MOTOR - IP 65 115 VOLT 60 Hz	1
W2CUS	SS TRANSMISSION BEARING	2
W6CUS	SS BEARING 6000 ZZ 10 x 20 X 6	2
X0060	CAP SCREW	1
X0070	LOCKWASHER	1

ABM COMPANY
UNI 350 G AUTO
Automatic Slicer

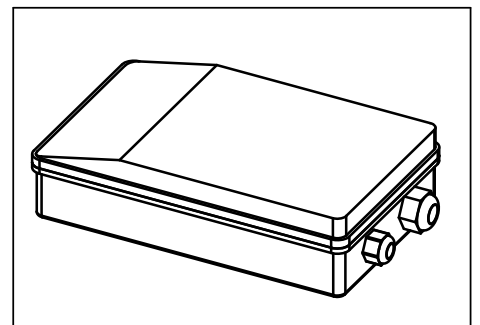
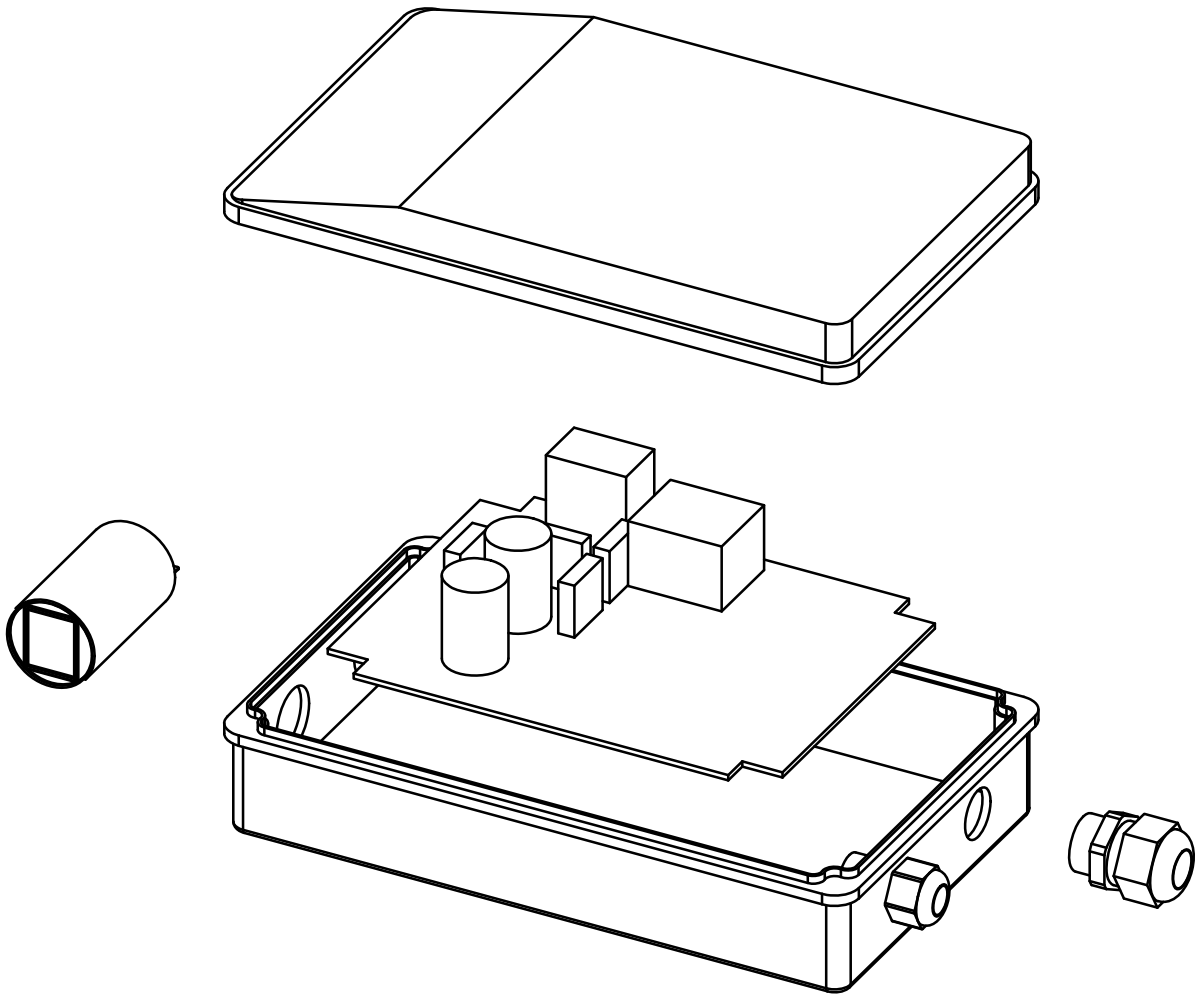

Complete Assembly

CODE	DESCRIPTION	Q.TY
GRSTA	COMPLETE CONTROL BOX	
W3CON	CAPACITOR 20 Mf	1
X0710	ELECTRIC BOX - BASE	1
X0720	PLASTIC COVER	1
Z9PLA	START SWITCH - IP 69	1
Z9PLH	STOP SWITCH - IP 69 RED	1
Z9KAP	SWITCH PROTECTION	2
Z9TCA	CARD 115/60Hz -	1

ABM COMPANY
UNI 350 G AUTO
Automatic Slicer

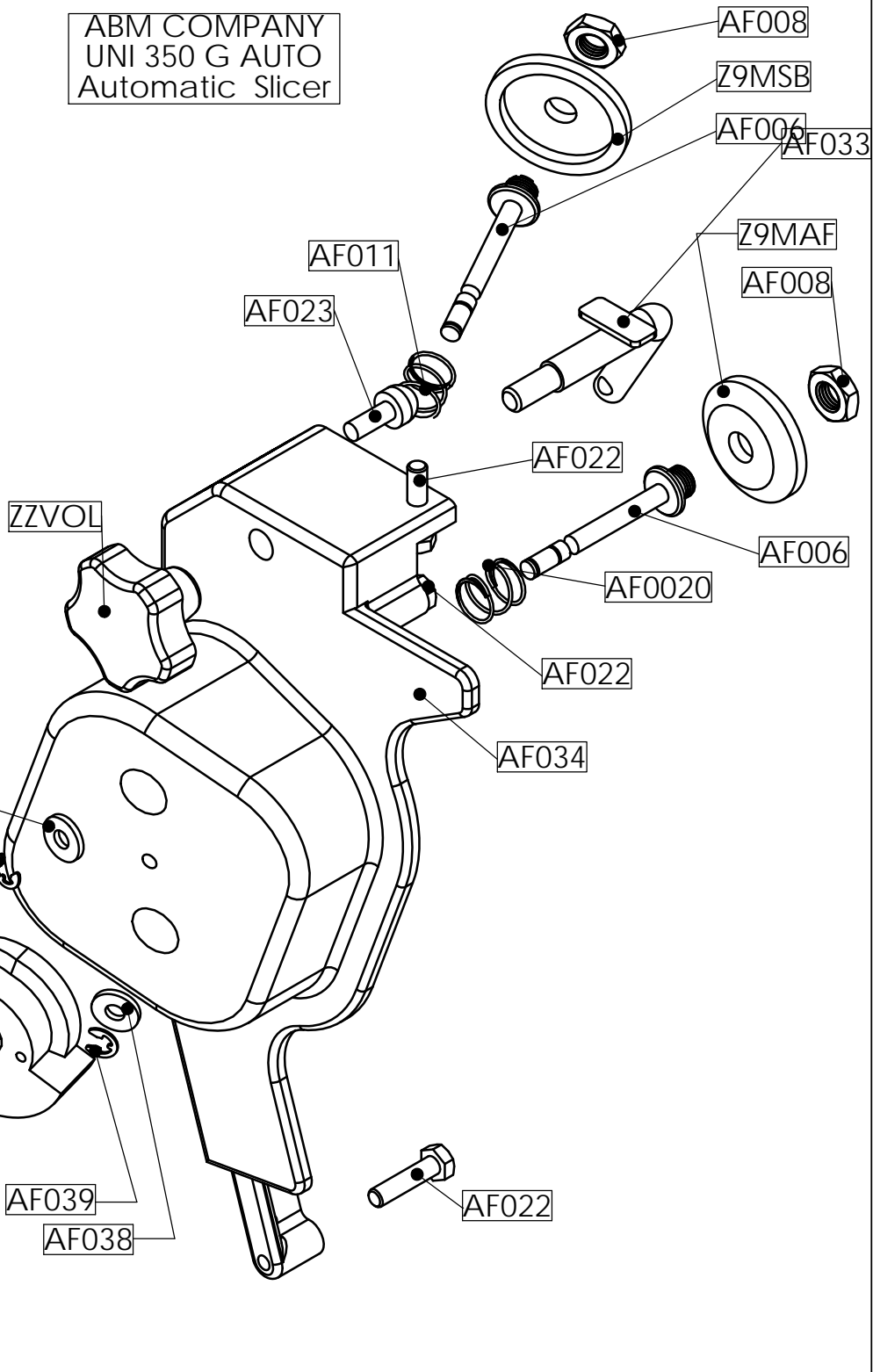
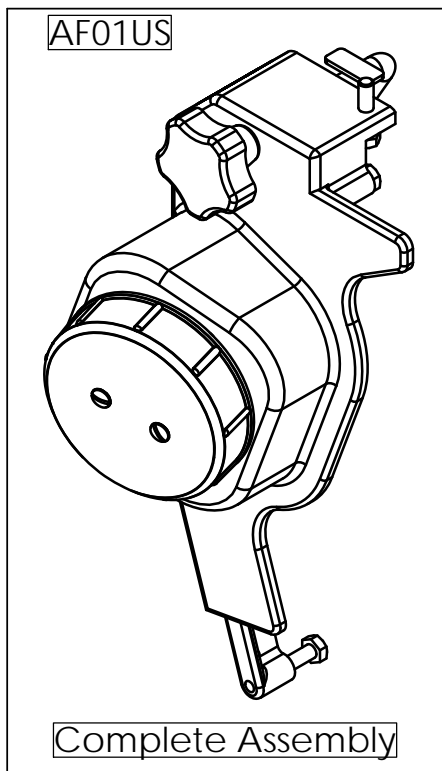

CODE	DESCRIPTION	DESCRIZIONE	Q.TY
AF006	SHAFT - SHARP + CLEANING STONE	ALBERO MOLA	2
AF008	NUT - SPECIAL	DADO	2
AF011	SPRING - CLEANING STONE	MOLLA ALBERO MOLA	1
AF01US	SHARPENER - COMPLETE ASSEMBLY	AFFILATOIO COMPLETO	
AF020	SPRING - SHARPENING STONE	MOLLA ALBERO MOLA	1
AF022	SCREW - PLASTIC	VITE	3
AF023	SCREW - MAIN GUIDE - PLASTIC	VITE PLASTICA	1
AF033	ARM	AGGANCIO	1
AF034	HOUSING -	CORPO AFFILATOIO	1
AF035	SHARPENER CAM	CAMMA	1
AF036	KNOB - SHARPENER	MANOPOLA	1
AF038	WASHER - PLASTIC	RONDELLA	2
AF039	RING - RETAINER - UNI 7434	ANELLO	2
AF040	SCREW - TC 5 x 10	VITE	2
Z9MAF	STONE - SHARPENING	MOLA	1
Z9MSB	CLEANING STONE	MOLA	1
ZZVOL	KNOB - BLADE G. + SHARPENER	VOLANTINO	1

ABM COMPANY
UNI 350 G AUTO
Automatic Slicer

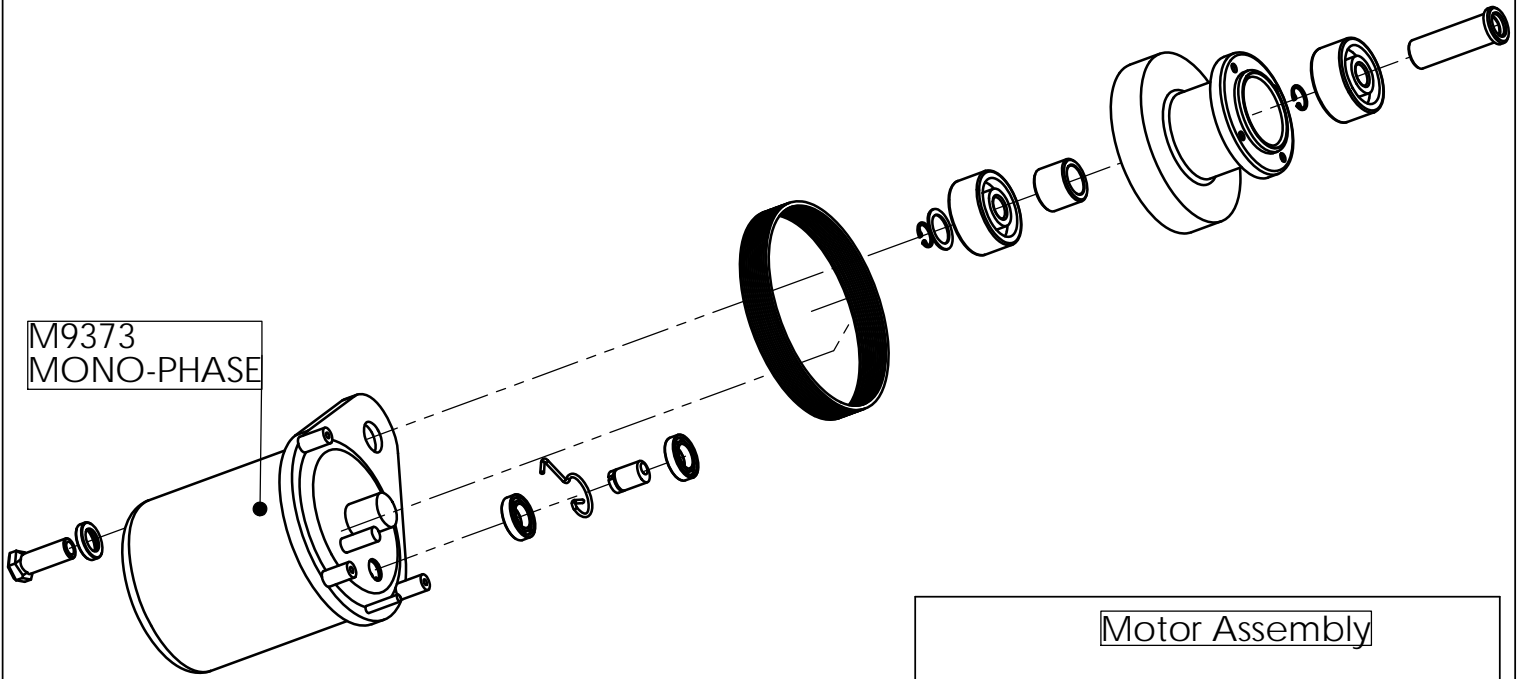

M9373
MONO-PHASE

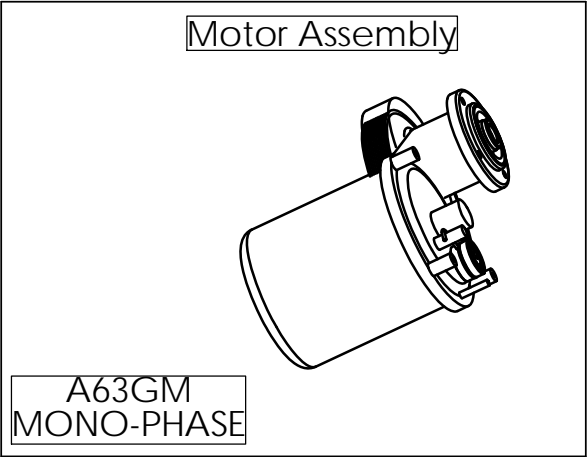

Motor Assembly

A63GM
MONO-PHASE

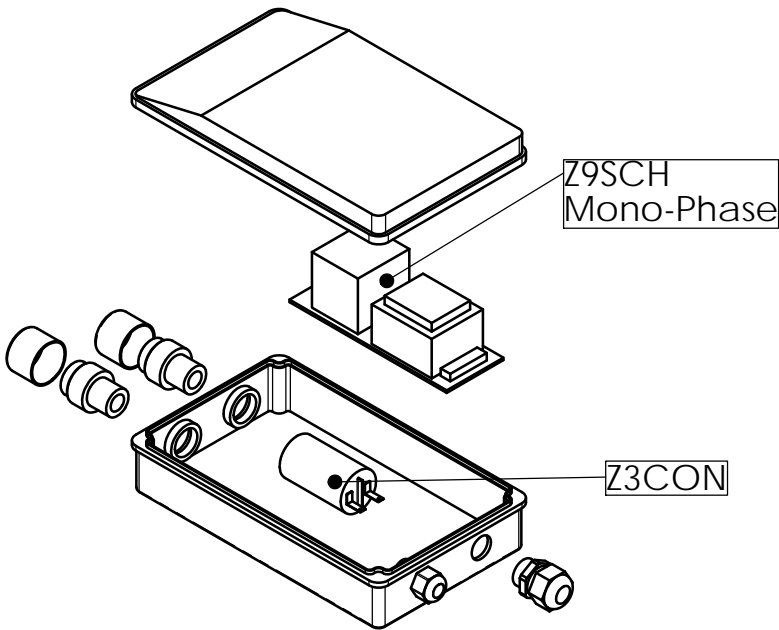

Z9SCH
Mono-Phase

Z3CON

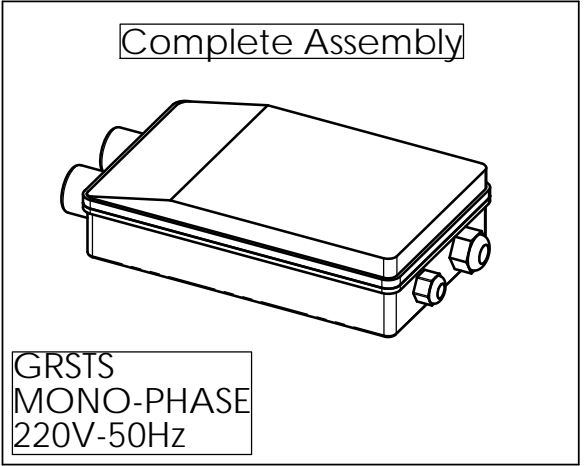

Complete Assembly

GRSTS
MONO-PHASE
220V-50Hz

CODE	DESCRIPTION	Q.TY
A63GM	MOTOR ASSEMBLY IP 65 220 - 50Hz	
GRSTS	COMPLETE CONTROL BOX 220/50 Hz	
M9373	MOTOR - IP 65 - 220/50 Hz IP 65	1
Z9SCH	CARD 220/50 Hz	1
Z3CON	CAPACITOR 10 Mf	1



Factory:

WWW.BIROSAW.COM

THE BIRO MANUFACTURING COMPANY, 1114 W. MAIN ST., MARBLEHEAD,
OH 43440-2099 U.S.A.