



# SM-5500H

PC Based System Hanging Scale



PC Based

## Dimension (mm)

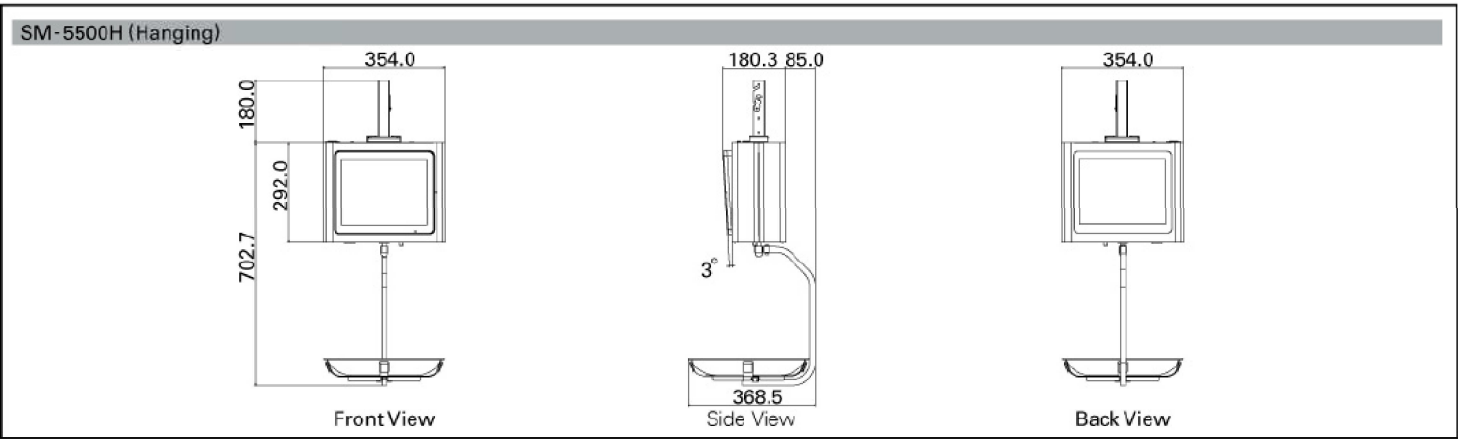

## Specifications

<b>Capacity</b>	Max 15kg / 30lb
Single Interval	1 / 3,000 e = 5g / 0.01lb
<b>Capacity</b>	Max 6 / 15kg
Multi Interval	1 / 3,000 e = 2 / 5g
<b>Model</b>	SM-5500H
<b>Dimension</b>	354(W) x 369(D) x 883(H) mm
Operator Display (800 x 600)	12.1" TFT SVGA with Resistive Touch Panel
Customer Display (800 x 600)	12.1" TFT SVGA
Display Resolution	1 / 3,000
CPU	Dual Core 1.2GHz
Memory	Factory default 1GB DDRAM / SD Card 8GB
Label Size (mm)	20 - 60mm (Width) / 20 - 240mm (Length)
Label / Receipt Roll Diameter	105mm (Max)
Paper Width	60mm (Max)
Printing Speed	Up to 150mm/Second*
Print Resolution	200dpi
Max Print Length	240mm
Power Source	AC 100 / 110 or 220 / 230 / 240Volts (50 / 60 Hz) Factory Default
Operating Temperature	- 10°C to + 40°C
Humidity	15% to 85% RH
Standard Interface	RS232C, Ethernet 10 / 100 Base T, USB 2.0 Host, Cash Drawer
Net Weight	16.3kg
<b>Optional Interface</b>	USB-WLAN (IEEE 802.11 a/b/g/n)
<b>Other / Variants</b>	SM-5500, SM-5000BS



\*To achieve maximum print speed, high sensitivity thermal paper is necessary. Contact DIGI for details.

## Options

### Electronic Displays

Attractive and informative electronic displays provide seamless updating of product information with every scale database change.



### Integrated Queue & Collection System

Directing customers to available counters dramatically improves customer convenience and reduces walk-aways and waiting time.



## New Brunswick International, Inc.

Corporate Headquarters  
76 Veronica Ave  
Somerset, NJ 08873  
TEL: (732) 828-3633  
FAX: (732) 828-4884

West Coast Office  
530 West Central Ave. Suite C  
Brea, CA 92821  
TEL: (714) 671-7911  
Fax: (714) 671-0798

[www.nbidigi.com](http://www.nbidigi.com)

