

## Double Chamber Vacuum Sealing Machine

*Ergonomically Designed*



### VACUUM-PACKAGING HAS NEVER BEEN SO EASY

MINIPACK vacuum machines are made of Stainless Steel AISI 304 and equipped with an authentic German **BUSCH**® vacuum pump. The volumetric electronic sensor assures a steady control of vacuum and gas packaging with 9 storable programs in a user friendly digital control board.



*Bulk Packaging*

*Sous Vide*

**minipack®  
america**

## Single Chamber Vacuum Sealing Machine

Feature	Description	Technical Data	
Lid Evacuation	Quicker vacuum time and flat working surface for easy sanitation	<b>Seal</b>	2 Lid Mounted Seal Bars @ 33" (840mm) (Front and Back)
9 Digital Programs	Nine storable programs for different products liquids, solids, gas, etc.		2 Seals - 1 Seal @ 5mm and 1 Seal/Cutoff @ 1mm
Digital Vacuum Sensor	Measures & compares the programmed vacuum percent for accuracy	Distance Between Sealbars 32.5" (830mm)	
Moisture Quick Stop	Stops vacuum instantly and seals pouch for liquid products	<b>Chamber</b>	Width 35" (890mm)
Toolless Trouble Shooting	Digitally test components through control board without tools		Length 37.5" (950mm)
Service Indicator	Digital display will display (OIL) when service is due		Lid Height 10.75" (275mm)
Extra Vac	Runs the evacuation up to 30/sec longer for porous or soft products	<b>Speed</b>	2 - 3 Cycles per/minute
Horizontal Lid Springs	Ergonomically designed to reduce weight and operator fatigue	<b>Power</b>	220Volt / 3 Phase / 40Amp
Soft Air	Controls the air return rate for delicate or sharp products		Pump 15hp 300m3h Busch R5 Rotary Oiled Vane
Pump Conditioning	Removes and eliminates moisture deposits in the oil	<b>Machine</b>	Width 75" (1900mm)
Stainless Steel Construction	Premium 304 stainless steel materials and robust construction		Length 51" (1295mm)
Quick Change Seal Bar	1 bolt removal system for easy access		Height 46" (1175mm) lid closed
Box Frame Construction	Twice the strength of regular C-frame		Height 57" (1450mm) lid open
Flat Working Deck	Flat deck with bolt-on stiffening bars reduce welding and warpage		Working Height 33.25" (845mm)
			Weight 1850lbs (840kg)
			Ship Weight 1930lbs (876kg)

### Options:

- ▶ **Gas Kit** - Nozzle allows entry of inert gas into pouch
- ▶ **Wide Seal** - 1 Seal @ 8mm
- ▶ **Double Seal** - 2 Seals @ 4mm Domed for high moisture pouches
- ▶ **Evacuation Filter Kit** - Prohibits fine particles and moisture from entering pump
- ▶ **Machine Protective Cover Kit**
- ▶ **EZ Swing** - Creates effortless lid transitions
- ▶ **Bi-Active Sealing** - Allows for sealing of gusseted or foil pouches
- ▶ **Air Assist Sealing** - Extra seal pressure from external air source

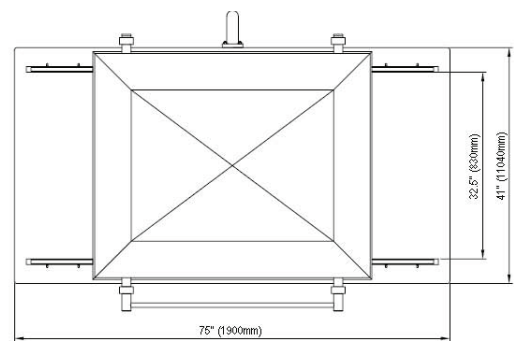
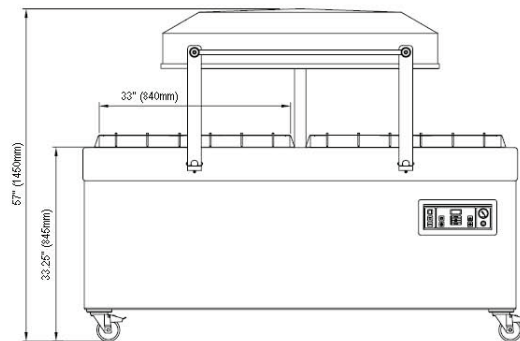
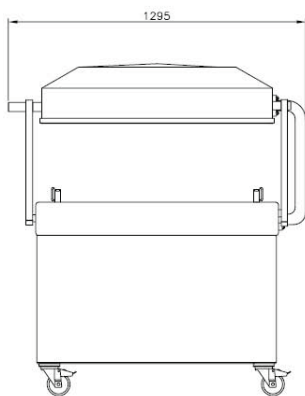

Electrical  
Approved



Sanitation  
Approved



CSA  
Approved



CE  
Certification



HACCP  
Assistance  
Available

**minipack<sup>®</sup>  
america**

Orange, CA USA 92865  
Phone: 714.283.4200  
Fax: 714.283.4268

[www.minipack-america.com](http://www.minipack-america.com)